

These instructions are for version / model:

V 3.16 e-Boost2 Part #: TS-0301-1001, TS-0301-1002, TS-0301-1003, TS-0301-1004, TS-0301-1005

V 4.16 e-Boost2 Part #: TS-0301-1006, TS-0301-1007, TS-0301-1008, TS-0301-1009, TS-0301-1010

1.0 BEFORE YOU START - IMPORTANT TIPS	2
2.0 INSTALLATION	2
2.1 Packing list.....	2
Optional Accessories	3
2.2 Mounting the e-Boost2.....	3
2.3 Installing the e-Boost2 solenoid	3
2.3 Installing the e-Boost2 solenoid	4
2.4 Single Internal Waste gate Connection.....	4
2.5 Twin Internal Waste gate Connection	5
2.6 External Waste gate Connection.....	6
2.7 "Two Port" Connection Method (1).....	6
2.8 "Two Port" Connection Method (2).....	7
2.9 Multiple External Waste gate Connection	7
2.10 Wiring.....	8
2.11 RPM Signal Connection.....	8
3.0 e-Boost2 MENU STRUCTURE.....	9
4.0 e-Boost2 - BASIC OPERATION.....	14
4.1 LIVE MODE	14
4.1.1 Live Boost.....	15
4.1.2 Live RPM	15
4.1.3 Current Set-point value	15
4.1.4 PHb – Peak Hold boost	15
4.1.5 PHr – Peak Hold RPM.....	15
4.2 BOOST MENU – Basic Operation	15
4.2.1 SP1 – SP6 - Boost Pressure Setting	16
4.2.2 GP1 – GP6 - Gate Pressure Setting	17
4.2.3 Sn1 – Sn6 – Sensitivity Setting	17
4.3 SETUP MENU – Basic Functions	18
4.3.1 ObS - Over-Boost Shutdown VERY IMPORTANT!.....	18
4.3.2 CYL – Cylinder Selection.....	19
4.3.3 SCL – Pressure Unit Scale for Main Readout (PSI/KPA/bAr).....	19
4.3.4 LE1/LE2 – Shift/Warning LEADS.....	19
4.3.5 bGr - Bar Graph	20
4.3.6 AL - Audible Alarm.....	20
4.3.7 nSP – Number of Set Points.....	21
4.3.8 rES – Factory Reset	21
4.3.9 ZEr – Re-Zero Display.....	21
5.0 e-Boost2 - ADVANCED OPERATION	22
5.1 AU –Auxiliary Output	22
5.2 dS1 –dS6 – Delayed Switching	22
5.3 PIn –Password Protection.....	23
5.4 COR – Offset Correction Function	23
5.5 rSP – RPM Based Set Point Mapping	24
5.6 SEr – serial number display.....	26
6.0 Switch Logic (SL)	26
6.1 – ISP – Internal switch points	26
6.2 – ESP – External switch points.....	26
6.3 – BOD – Boost on demand	26
6.4 – SSA – Sequential switching function A.....	27
6.5 – SSB - Sequential switching function B	28
6.6 – SSC - Sequential switching function C.....	29
6.7 – SSD - Sequential switching function D.....	30
6.8 – SSE - Sequential switching function E	32
7.0 TROUBLESHOOTING	34
8.0 VEHICLE SPECIFIC WIRING DIAGRAMS.....	34

1.0 BEFORE YOU START - IMPORTANT TIPS

- Turbosmart recommends that your e-Boost2 is fitted by an appropriately qualified technician.
- Consult your local tuning specialist before setting your boost pressure, setting boost beyond your engines capability can result in severe engine damage or failure!
- Turbosmart recommends that the engines Air/Fuel ratio is checked once the desired boost pressure is set, any increase in boost pressure can cause the engine to run lean resulting in severe engine damage or failure!
- Turbosmart recommends that the e-Boost2 is not used in conjunction with any type of "Draw Through" Fuel System.
- Turbosmart recommends that boost pressure is set using a Dynamometer and not on public roads.
- The e-Boost2 may not be able to completely compensate for a drop in boost pressure at high RPM due to the turbocharger operating beyond its maximum efficiency range i.e. incorrect turbocharger sizing or excessive exhaust backpressure.
- The e-Boost2 cannot compensate for increases in boost pressure at high RPM due to inadequate waste gate flow capacity; the turbo system must maintain a steady base boost curve.
- The e-Boost2 cannot be used with external waste gates that are in a poor, worn or non-serviceable condition.
- For best results your turbocharger should be correctly sized for your application.
- A Turbosmart Fuel Cut Defender may need to be used in conjunction with your e-Boost2, Please check out our website at www.turbosmart.com.au or your nearest Authorised Turbosmart Dealer for more information on Fuel Cut Defenders.
- Erratic operation of electronic parts can be caused by Electro Magnetic Interference (EMI). EMI can be generated by aftermarket ignition systems such as CDI which, if wired incorrectly, generate large amounts of EMI through the vehicles electrical system. This can cause items such as ECU's and boost controllers to be effected. Please follow ignition system installation instructions VERY carefully to avoid EMI affecting the e-Boost.

2.0 INSTALLATION

2.1 Packing list

e-Boost2 40 and 60	Description	Use
1	e-Boost2	
1	e-Boost2 solenoid	Use in conjunction with e-Boost2
2	M3x20 Cap screws	Secure e-Boost2 solenoid
1	Solenoid mounting bracket	Secure e-Boost2 solenoid
1	Solenoid mounting grommet	Secure e-Boost2 solenoid
1	Solenoid mounting sleeve	Secure e-Boost2 solenoid
1	M6X25 Screw	Secure e-Boost2 solenoid to mounting point
1	Wiring loom	Connect e-Boost2 to vehicle
1	Earth eyelet	Connect to wiring loom
100 mm	Heat shrink	Shield solder joints
2000 mm	Figure eight wire	Connect wiring loom to e-Boost2 solenoid
1	5 Amp fuse	Connect to 12 Volts – see wiring diagram
10	Cable ties	Secure wiring
1	Panel mounting bracket	Secure e-Boost2 to panel
1	M6x20 Grub screw	Used with panel mount bracket
1	M6 Lock nut	Locks panel mount grub screw in place
2	M6 Nyloc Nut	Secure panel mount bracket & solenoid mount
1500 mm	4mm OD Polyurethane hose	Connected to back of e-Boost2
1	Fuse holder	Holds 5 amp fuse
1	Connecting barb	Connect silicon hose to Polyurethane hose
1000 mm	3mm ID Silicon hose	Join polyurethane hose to intake manifold
1	4mm Tee Piece	Join 4mm ID Silicon hose to intake manifold
4	Small spring hose clamps	Use on 3mm ID Silicon hose
750 mm	5mm ID Silicon hose	Connect solenoid
4	Large spring hose clamps	Use on 5mm ID Silicon hose
2	5 – 6.3mm hose reducer	Reduce 6.3mm hose to 5mm hose
1	M6 Washer	For mounting brackets
3	1/8 NPT to barb fittings	Connection of silicone hose to solenoid
2.4 m	¼ inch ID Silicon hose	Join polyurethane hose to intake manifold & connect solenoid (e-Boost 2 60PSI)
1	¼ inch Tee Piece	Join 3mm ID Silicon hose to intake manifold (e-Boost 2 60PSI)
10	Screw type hose clamps	Use on ¼ inch ID Silicon hose (e-Boost 2 60PSI)

Optional Accessories



Dash Mount
60mm - TS-0301-2001
66mm - TS-0301-2013



LED Ring Mount
Dual Silver 66mm - TS-0301-2006
Dual Black 66mm - TS-0301-2007
Dual Silver 66mm - TS-0301-2017
Dual Black 66mm - TS-0301-2018



LED Roll Cage Mount
60mm - TS-0301-2002
66mm - TS-0301-2014

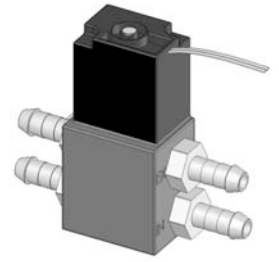

4 Port Solenoid
TS-0301-2003

2.2 Mounting the e-Boost2

- The e-Boost2 is not waterproof and must be mounted inside the cabin. The unit has an operating temperature range of -5°C to +70°C.
- The e-Boost2 is designed to be panel mounted with the bracket supplied. Alternatively the 60mm e-Boost2 can be mounted using the Turbosmart 60mm dash mounting accessory, pod or "A pillar" mounts. If you have the 66mm e-Boost2 it can be mounted using the Turbosmart 66mm dash mount accessory. The Turbosmart dash mounting accessory offers full tilt and swivel adjustment.
- The 4mm OD polyurethane hose is only to be used inside the cabin of the vehicle, it is not rated to withstand engine bay temperatures. The connecting barb joins the 4mm OD polyurethane hose to the thicker silicon hose. This silicon hose is rated to withstand engine bay temperatures and is easier to connect to the intake manifold.
- Route the 4mm polyurethane hose through the cabin from the e-Boost2 mounting position to the firewall/bulkhead taking care not to kink the hose.
- Use the connecting barb to join the 4mm OD polyurethane hose to the 3mm ID silicon hose at the firewall/bulkhead. Ensure the 4mm OD polyurethane hose is pressed all the way onto the connecting barb and that the polyurethane hose does not enter the engine bay.
- Route the silicon hose through the engine bay and connect it to a pressure/vacuum signal from the inlet manifold. Use the supplied tee piece if necessary.
- Secure all connections with the supplied hose clamps.

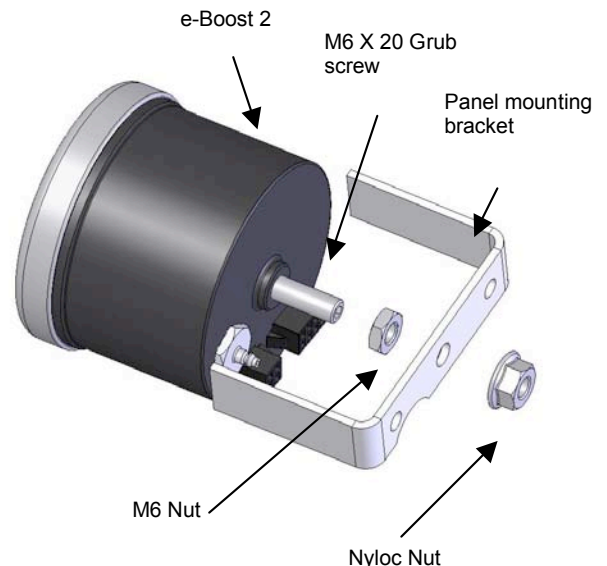
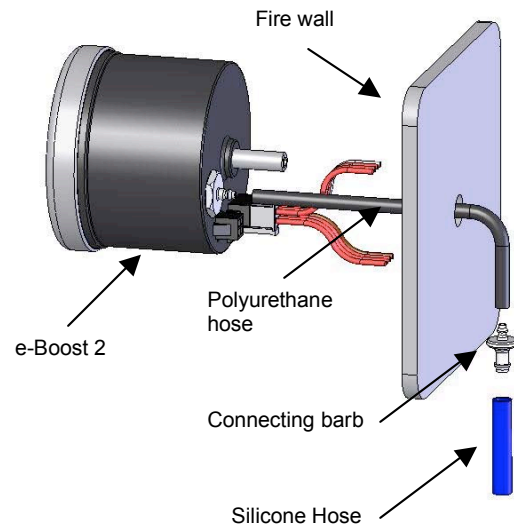

2.3 Installing the e-Boost2 solenoid

- The e-Boost2 solenoid is rated to a maximum temperature of 100 degrees Celsius (212 degrees Fahrenheit), ensure that it is mounted a minimum of 250mm (10 inches) away from the heat of the turbo or exhaust manifold, otherwise heat shielding maybe required.
- Mount the e-Boost2 solenoid in an appropriate position in the engine bay with the mounting kit supplied.
- Fit the rubber grommet inside the mounting plate. Slide the sleeve inside the grommet. Use the M3 screws to bolt the solenoid to the mounting bracket – Note use locite on the threads to secure. Use the M6 screw, washer and Nyloc nut to mount in a suitable location in the engine bay.

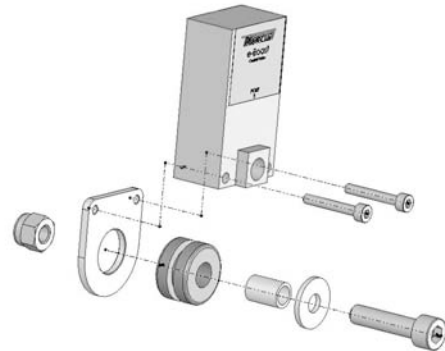

2.4 Single Internal Waste gate Connection

Most factory turbocharged vehicles use an internal waste gate system to control boost pressure. The e-Boost2 controls boost pressure by controlling the pressure signal that the waste gate actuator receives from the turbocharger. Please note that the e-Boost2 cannot be used to obtain a boost pressure lower than the standard waste gate actuator's pressure setting.

If your vehicle is fitted with a factory boost control solenoid it MUST BE REMOVED from the hose that runs between the pressure source and the waste gate actuator.

WARNING! Failure to remove the solenoid will cause erratic or fluctuating boost pressure, and **over boosting may occur.**

- Ensure that this solenoid remains connected to the ECU's wiring harness, If not the "Check Engine" light may be triggered.
- The factory boost control solenoid is NOT a sensor of any kind, its removal from the waste gate actuator hose will NOT cause any adverse effects.
- Some waste gate actuators have two inlet fittings, eg Toyota GT4 (All-Trac) Celica, MR2, JZA80 Supra. Identify the hose that connects from the boost control solenoid to the waste gate actuator, and block both ends of this hose.
- Some factory hoses have a small restrictor fitted inside them, if the factory hoses are reused over boosting or boost spiking may occur.
- Turbosmart recommends using the silicon hose (and reducers if necessary) to connect the e-Boost2 solenoid.
- Secure all connections with the supplied hose clamps.

Connect the three ports on the e-Boost2 solenoid according to the diagram below.

- Port (1) vents pressure from the e-Boost2 solenoid. Connect this hose to the intake side of the turbo, between the air cleaner and the inlet of the turbocharger. Otherwise connect a short piece of the silicon hose and face the vent downwards to stop water or debris entering the solenoid. If you have removed a factory boost control solenoid connect this hose to where the factory solenoid originally vented.
- Port (2) Connects to the internal waste gate actuator (See above if your actuator has two inlet fittings)
- Port (3) Connects to a "boost only" pressure source, typically from the compressor housing on the turbocharger. If your turbocharger does not have this fitting, connect to a "boost only" pressure source before the throttle-body or butterfly. Do not connect to the intake manifold, as the pressure signal will have both vacuum and boost pressure.

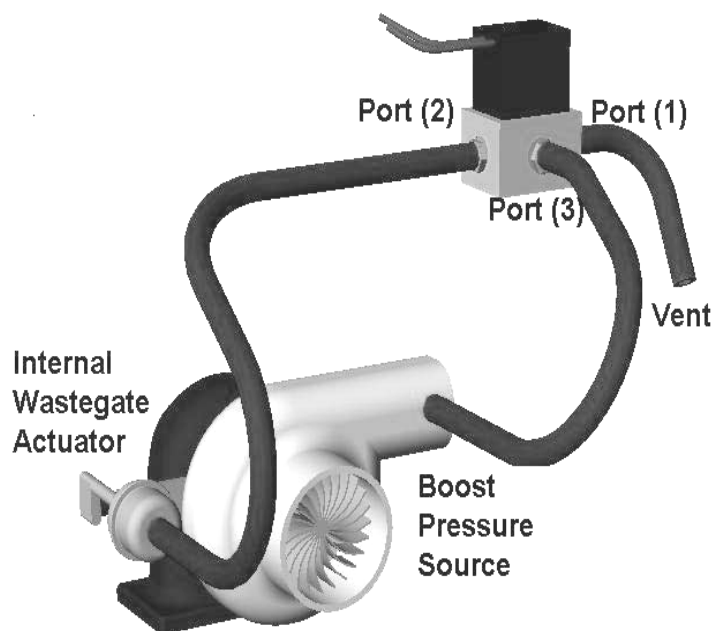

If you are unable to achieve your desired boost pressure it is normally due to exhaust manifold backpressure forcing the internal waste gate to open. To increase your boost pressure further, fit a higher pressure waste gate actuator to increase your minimum boost pressure.

WARNING! Fitting a higher pressure waste gate actuator may cause a higher than expected increase in boost pressure. Turbosmart recommends resetting the Boost Set Point values to Zero and measure the new minimum boost pressure before increasing your Boost Set Point values.

If you are still unable to achieve your desired boost pressure ensure that your turbocharger is correctly sized for your application.

2.5 Twin Internal Waste gate Connection

Single Solenoid Connection

- The e-Boost2 solenoid is capable of controlling two internal waste gate actuators as typically found on most factory parallel twin turbo vehicles such as the Nissan Skyline GTR, 300ZX, and Toyota Soarer.
- The solenoid is connected as per the single internal waste gate instructions above, with the addition of a tee-piece (not supplied) to connect both waste gate actuators to port number (2).
- If there is a fitting on both compressor housings on the turbochargers, use the most convenient fitting to connect to port number (3), and block the other fitting. If your turbochargers do not have these fittings, connect port number (3) to a "boost only" pressure source before the throttle-body or butterfly. Do not connect to the intake manifold, as the pressure signal will have both vacuum and boost pressure.

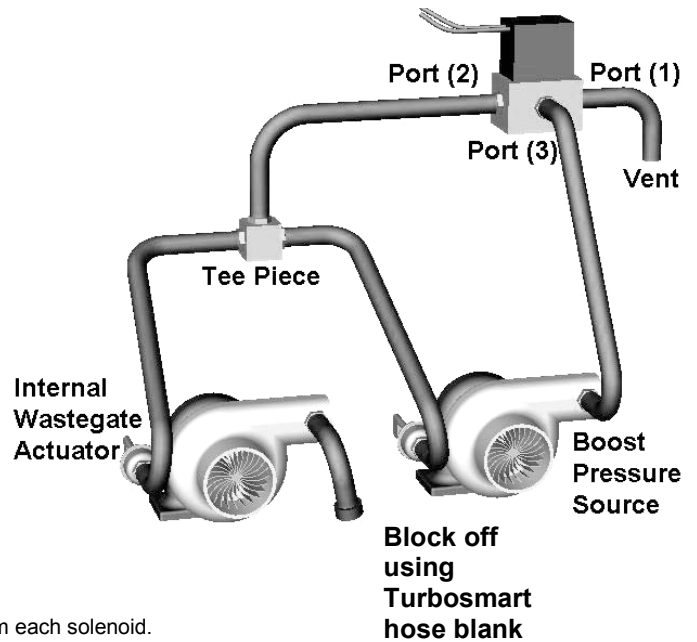

Twin Solenoid Connection

- The e-boost2 is also capable of controlling two solenoids wired up in parallel.
- Each solenoid controls one internal waste gate.
- Connect the grey wire from the e-boost2 to one of the wire from each solenoid.
- Connect the brown wire from the e-boost2 to the remaining wire from each solenoid.
- You will need an extra solenoid (part number: FG-EBC-SSK-40).

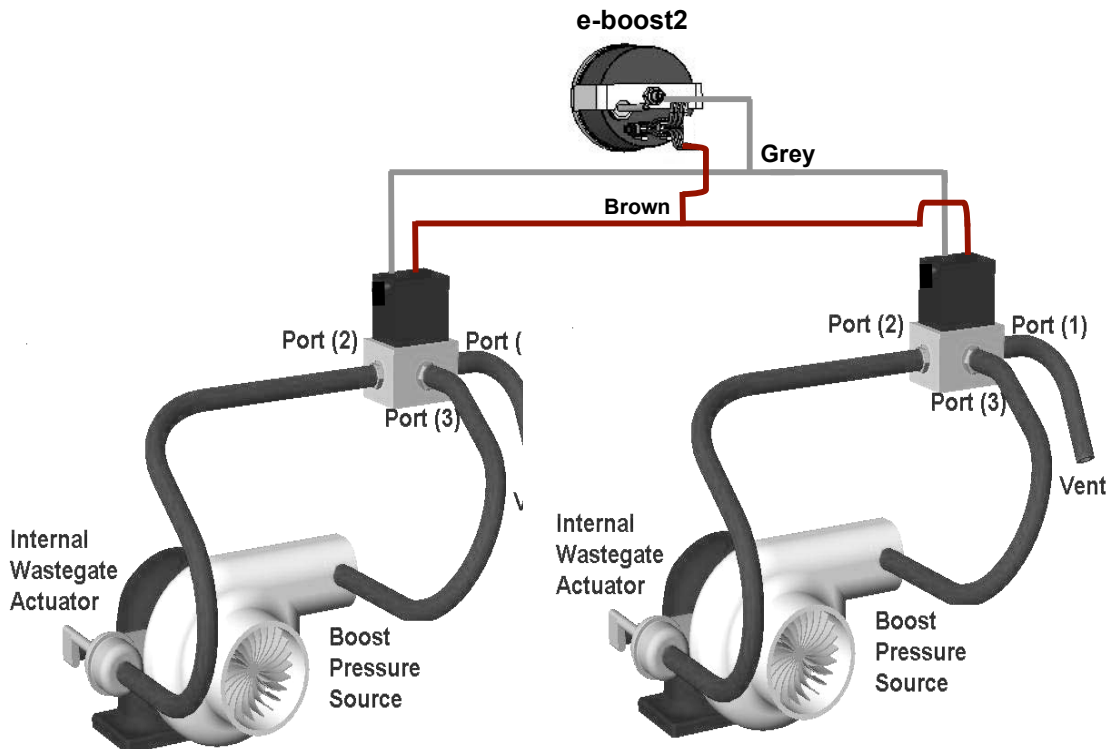

2.6 External Waste gate Connection

Most external waste gates share a similar design layout. Use the diagram to help identify the "top" and "bottom" port of your waste gate.

- When pressure is applied to the "bottom" port of a waste gate, i.e. underneath the waste gate diaphragm, it acts against the waste gate spring and the waste gate valve opens.
- When pressure is applied to the "top" port of a waste gate, i.e. above the waste gate diaphragm, it acts with the waste gate spring and helps to close the waste gate valve.

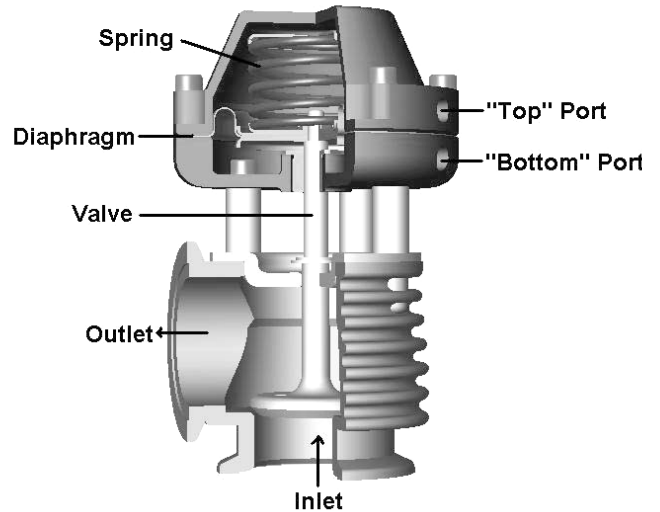

There are two methods for connecting the e-Boost2 to an external waste gate. The method used depends on the following factors.

- The size of the spring fitted in your waste gate i.e. The boost pressure achieved by the waste gate spring only.
- The desired level of boost pressure and the difference between this and your waste gate spring pressure.
- The size of your turbocharger and waste gate and the resulting exhaust manifold backpressure in your system.

Turbosmart recommends using the "Two port" connection method (1) as a starting point. If this connection method does not achieve the desired boost pressure, fit a heavier waste gate spring to increase your minimum boost pressure, or use the next connection method.

WARNING! Fitting a heavier waste gate spring may cause a higher than expected increase in boost pressure. Turbosmart recommends resetting the boost set point values to zero and measuring the new minimum boost pressure achieved by the new spring, before increasing your boost set point values.

2.7 "Two Port" Connection Method (1)

Connect the three ports on the e-Boost2 solenoid according to the diagram below.

- Port (1) Connects to a "boost only" pressure source, typically from the compressor housing on the turbocharger. If your turbocharger does not have this fitting, connect to a "boost only" pressure source before the throttle-body or butterfly. Do not connect to the intake manifold, as the pressure signal will have both vacuum and boost pressure.
- Port (2) Connects to the "Top" port on the external waste gate. For Further information on external waste gate port identification see section 2.6.
- Port (3) vents pressure from the e-Boost2 solenoid. Connect this hose to the intake side of the turbo, between the air cleaner and the inlet on the front of the turbocharger. Otherwise connect a short piece of the silicon hose and face the vent downwards to stop water or debris entering the solenoid.
- Connect the "Bottom" port on the external waste gate to the same "boost only" pressure source as Port (1) on the solenoid. For Further information on external waste gate port identification see section 2.6.
- Use a tee-piece (not supplied) to share the "boost only" pressure source if necessary.

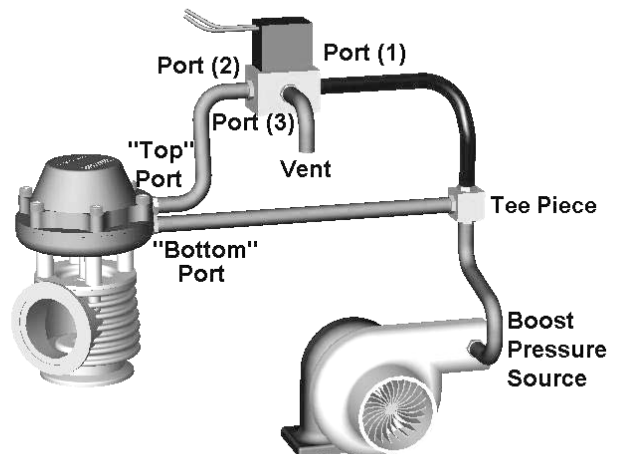

If you are unable to achieve your desired boost pressure it is normally due to exhaust manifold backpressure forcing the waste gate valve open. To increase your boost pressure further, fit a heavier waste gate spring to increase your minimum boost pressure, or use the "Two Port" connection method (2) as below.

2.8 “Two Port” Connection Method (2)

The “Two Port” connection method (2) is used to achieve the maximum possible boost pressure that your system can develop. It is the most suitable method if you are unable to develop your desired boost pressure due to high exhaust manifold back pressure.

WARNING! An increase in your minimum boost pressure is expected when using this method. Ensure all Boost Set Point Values are set to zero and measure the new minimum boost pressure achieved by this method of connection before increasing your Boost Set Point values.

Connect the three ports on the e-Boost2 solenoid according to the diagram below.

- Port (1) Connects to the “Top” port on the external waste gate. For Further information on external waste gate port identification see section 2.6.
- Port (2) Connects to a “boost only” pressure source, typically from the compressor housing on the turbocharger. If your turbocharger does not have this fitting, connect to a “boost only” pressure source before the throttle-body or butterfly. Do not connect to the intake manifold, as the pressure signal will have both vacuum and boost pressure.
- Port (3) Connects to the “Bottom” port on the external waste gate. For Further information on external waste gate port identification see section 2.6.

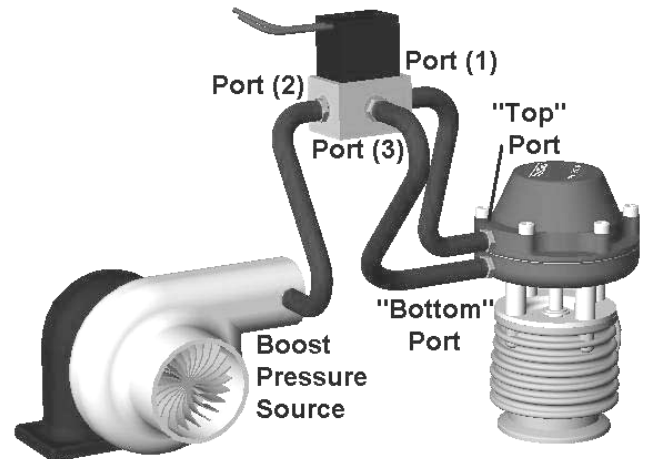

If you are unable to achieve your desired boost pressure it is normally due to exhaust manifold backpressure forcing the waste gate valve open. To increase your boost pressure further, fit a heavier waste gate spring to increase your minimum boost pressure. If you are still unable to achieve your desired boost pressure ensure that your turbocharger is correctly sized for your application.

2.9 Multiple External Waste gate Connection

The e-Boost2 is capable of controlling two external waste gates by utilising two solenoids. Each solenoid is used to control one external waste gate. Similar to the twin solenoid connection for the internal waste gates, the grey wire from the e-boost2 is connected to one of the two wires from each solenoid. The brown wire from the e-boost2 is connected to the remaining wire of each solenoid. You will need an extra solenoid (part number: FG-EBC-SSK-40).

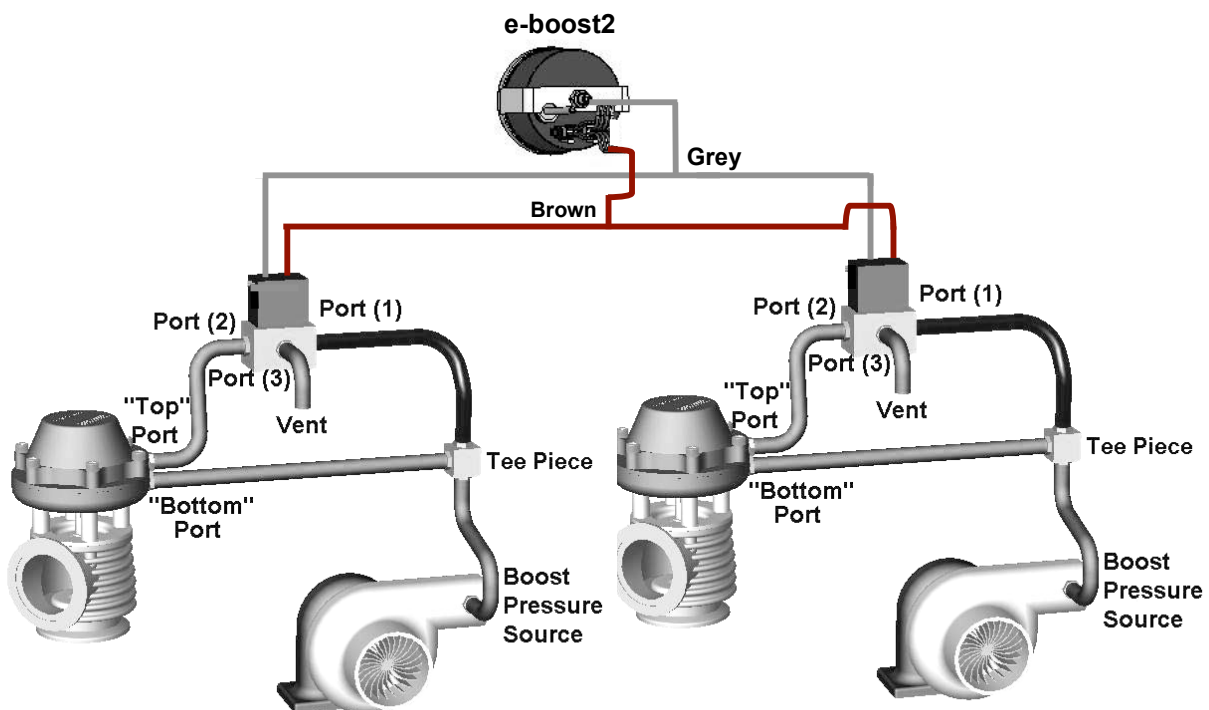

2.10 Wiring

- The e-Boost2 must be connected to a 12 volt negative earth electrical system.
- All electrical connections must be soldered.
- Refer to the following table and diagram for detail on wiring the e-Boost2.

Wire	Connect to
RED	+ 12 Volts switched through ignition – connect via 5 Amp fuse supplied
BLACK	Chassis, earth or ground
GREY	Solenoid wire 1 – connect using wire supplied – polarity not important
BROWN	Solenoid wire 2 - connect using wire supplied – polarity not important
YELLOW	RPM signal from ECU or negative terminal of an ignition coil
WHITE	Auxiliary output – switched to ground – see diagram below
GREEN	External set point switching - refer to section 5.6
ORANGE	External set point switching - refer to section 5.6

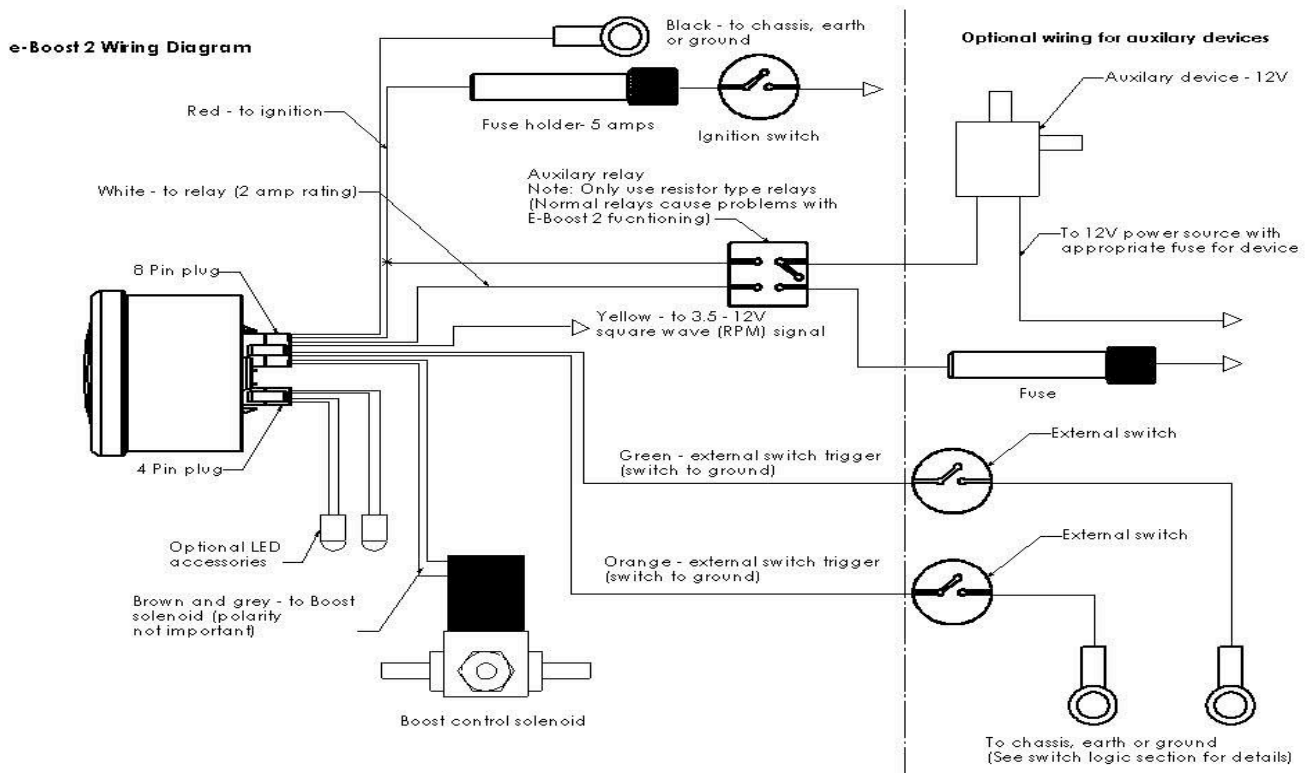

2.11 RPM Signal Connection

RPM signal connection is required for Tacho mode, RPM set point mapping, shift light function and other advanced features. Turbosmart recommends your RPM signal be connected by an appropriately qualified technician or automotive electrician. See section 7.0 for vehicle specific ECU wiring diagrams as a guide for the RPM signal connection. For further information consult your vehicle's manuals or your local automotive electrician. The e-Boost2 is able to accept an RPM signal in the form of a square wave that is switching between 0V and 3.5-12 volts.

The following points should be followed to connect your RPM signal to an ECU pin.

- Locate your ECU RPM signal wire and splice into the signal wire coming from your ECU.
- Check the output you are splicing into is a square wave that is switching between 0V and 3.5-12 volts with an appropriate meter.
- Connect the yellow RPM wire from the e-Boost to the spliced section of the ECU RPM out.
- Turn on the e-Boost2 and configure your signal to the number of cylinders or rotors your engine has using the CYL (cylinder) parameter located in the setup menu – refer to section 4.3.2 for details.
- In live mode with your engine running press mode once to show live RPM. The display should be reading RPMx100 e.g. 015 on the display indicates 1500 RPM. If the display is not reading correctly re-check the cylinder configuration in the setup menu.

BOOST MENU STRUCTURE

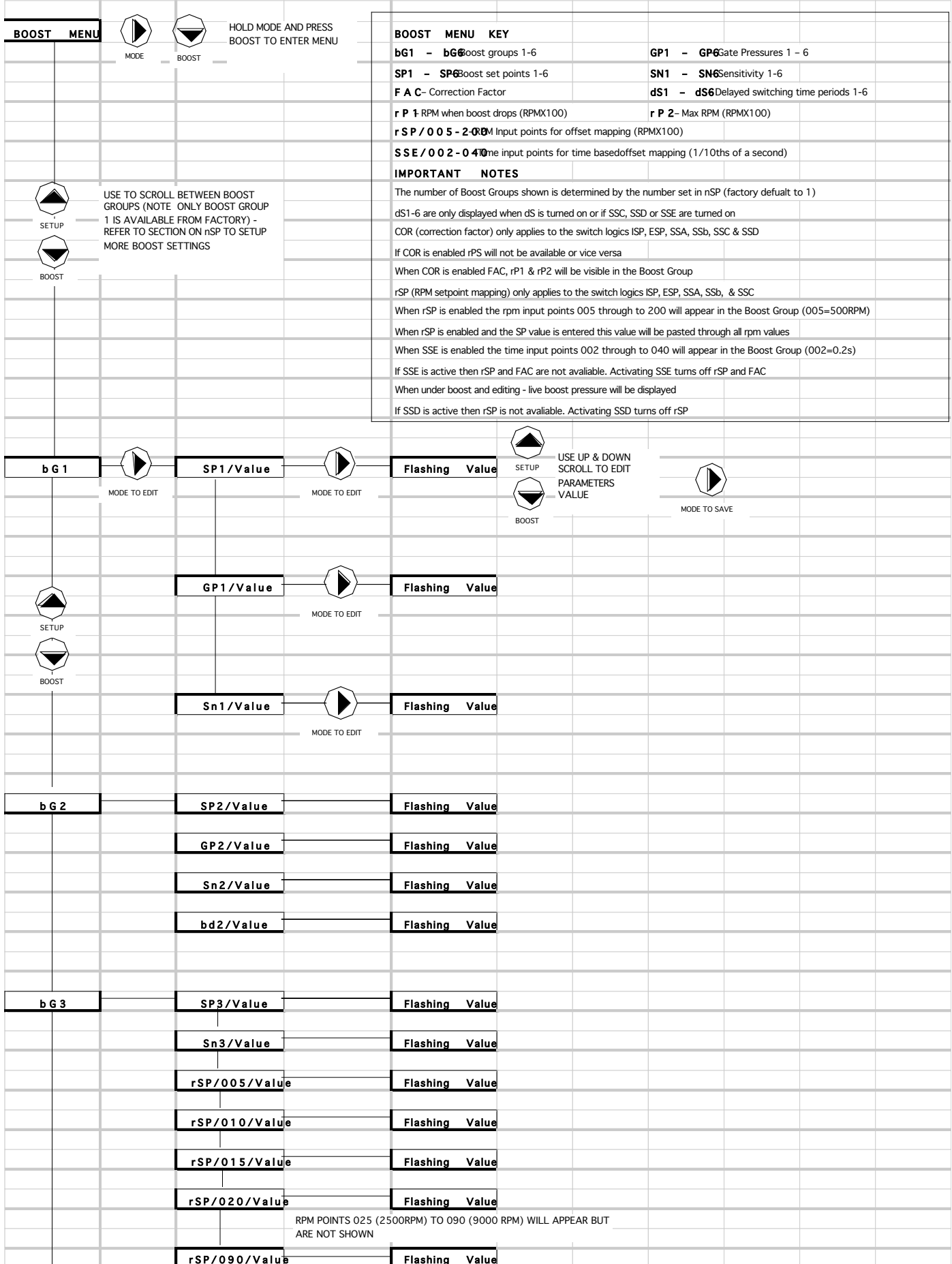

SETUP MENU STRUCTURE

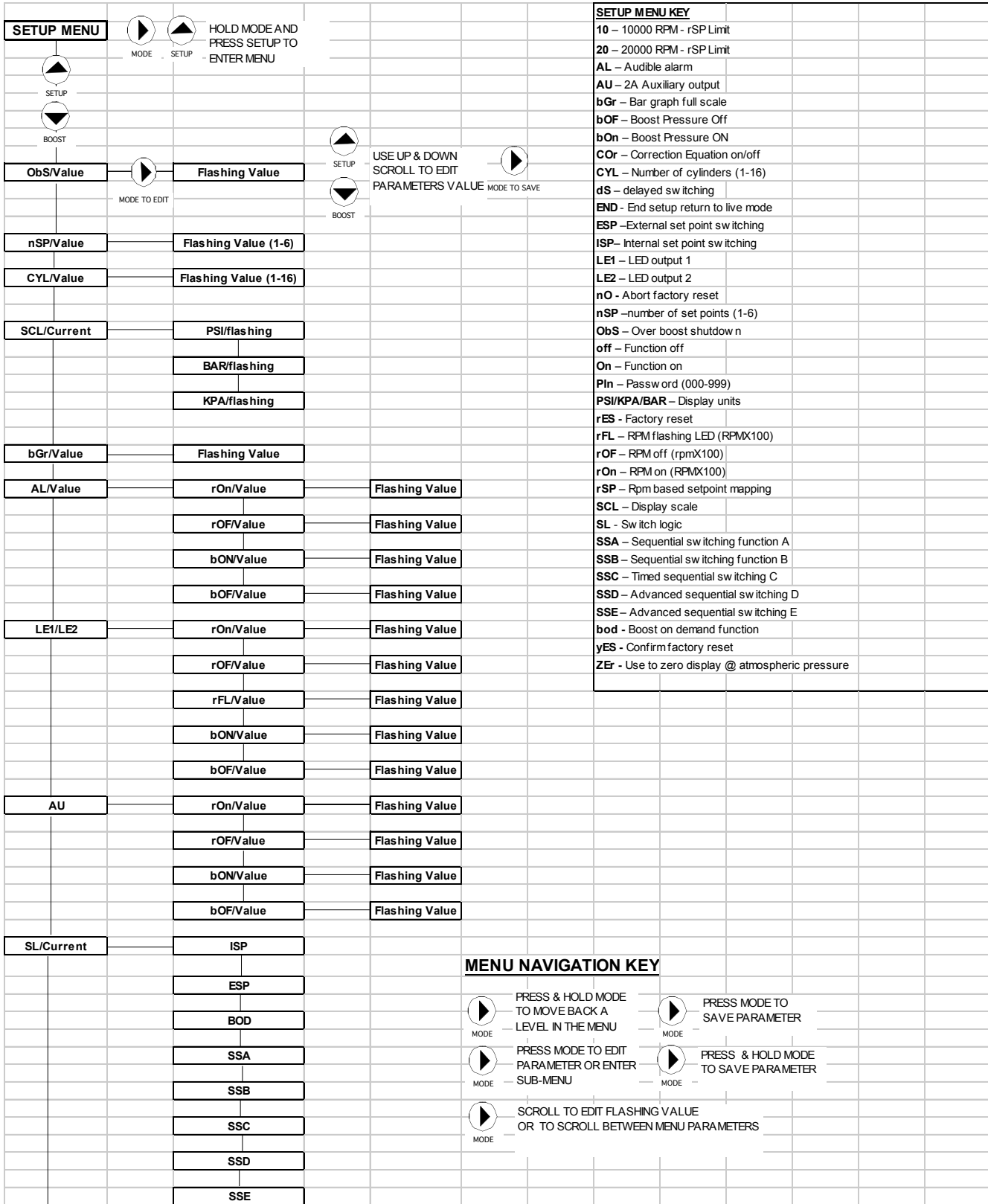

4.0 e-Boost2 - BASIC OPERATION

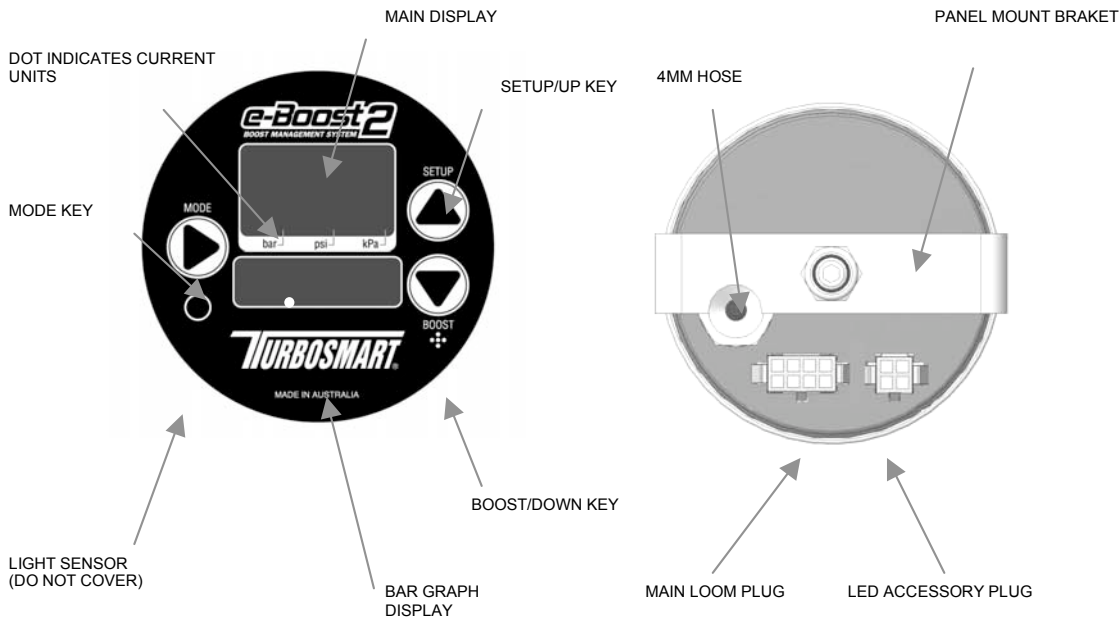

The e-boost2 is turned on by switching on your ignition, the display will light up and the e-Boost2 will turn on. The e-boost2 is turned off by pressing and holding the **MODE** button for **five seconds** or turning off your ignition. If you turn the unit off with you ignition on pressing the **MODE** button momentarily will turn the unit back on.

Display Mode: Your e-boost2 has a display mode that may be used if showing your car. Pressing the **UP** and **DOWN** buttons together quickly will enter the display mode. "E-boost2" will scroll across the screen and the bar graph will scroll up and down. Pressing the **UP** and **DOWN** buttons together will exit display mode.

4.1 LIVE MODE

When the e-Boost2 is powered up it will automatically go to Live mode. In this mode the readout and bar graph will display accurate live boost or vacuum readings. In live mode you can change between up to six boost pressure settings called boost set points. These appear on the readout as **SP1**, **SP2**, **SP3**, **SP4**, **SP5** and **SP6**. When the e-Boost2 is powered up it always defaults to **SP1**. We recommend that you enter a boost pressure that is used most often in SP1. The last boost set point that was viewed will be active. The number of set points visible in live mode will depend on the number of set points activated in the **nSP** (number of set points) parameter in the Setup menu.

To change between the boost set points press the **SETUP/UP** or **BOOST/DOWN** arrow, the set point will be displayed for one second and then the readout will return to **Live** boost or vacuum readings. Note this is only possible in **ISP** (Internal Set Point) mode which is the factory default setting for the e-boost2.

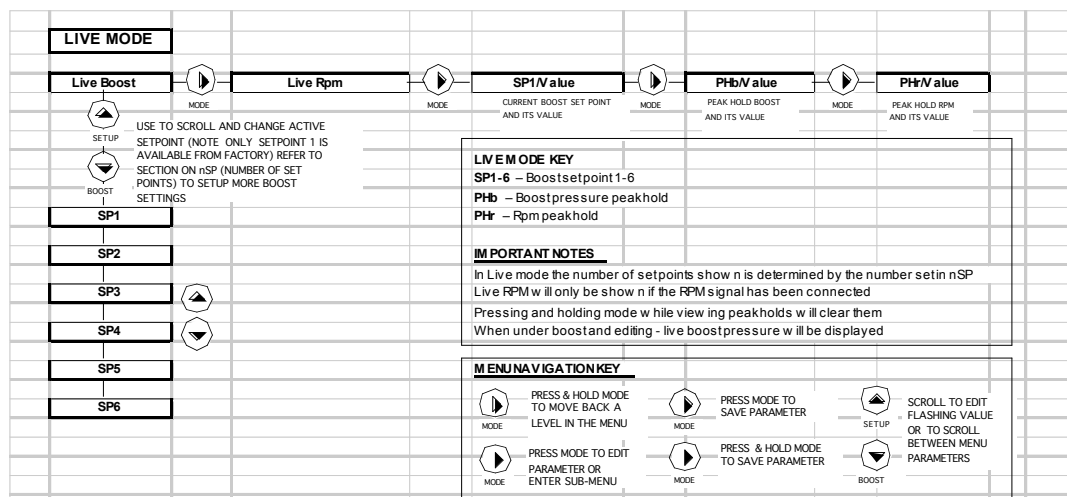

4.1.1 Live Boost

Live boost is the default display and the readout and bar graph will display live boost or vacuum readings.

4.1.2 Live RPM

In this mode the e-boost2 will be in tacho mode; displaying the current RPM of the engine. If you have not connected your RPM signal then this parameter will not appear.

*Pressing the **MODE** button once will scroll to live RPM and display current RPM x 100. e.g. a display of 020 indicates 2000rpm*

4.1.3 Current Set-point value

The active set point and its value will be displayed for quick and easy checking.

*To check the active set point; press the **MODE** button twice to scroll to the current set point (SP) and its value. The display will flash between the set point eg SP1 and its value.*

4.1.4 PHb – Peak Hold boost

The e-Boost2 has a peak hold boost function **PHb**, which records peak boost pressure. Each time a higher pressure is produced the previous figure is discarded and the new pressure is recorded.

*To view the **PHb** press the **MODE** button three times to scroll to **PHb**, the display will flash between **PHb** and the peak hold boost value. Pressing and holding the **MODE** button while viewing **PHb** or turning the unit off will clear the peak hold value.*

4.1.5 PHr – Peak Hold RPM

The e-Boost2 has a peak hold RPM function **PHr**, which records peak RPM. Each time a higher RPM is produced the previous figure is discarded and the new peak RPM is recorded.

*To view the **PHr** press the **MODE** button four times to scroll to **PHr**, the display will flash between **PHr** and the peak RPM value. Pressing and holding the **MODE** button while viewing **PHr** or turning the unit off will clear the peak hold value.*

4.2 BOOST MENU – Basic Operation

The e-Boost2 can store up to six different boost pressure settings, the boost menu is divided up into what we refer to as boost groups. Each boost group contains parameters that are relevant each boost pressure setting including the set point, gate pressure, sensitivity and other advanced functions. The number of boost groups visible in the boost menu will depend on the number of set points activated in the **nSP** parameter of the **setup menu** - See section 4.3.7 for further detail. Important note: The boost groups are independent from each other and BG1 can be set at a higher boost than BG2, BG3 could be set higher or lower than BG1 or BG2 and so on (i.e. there is no requirement to set BG2 to a higher boost pressure than BG1 – it can be higher or lower).

- The **boost menu** is accessed by pressing and holding the **MODE** button and the **BOOST/DOWN** button simultaneously.
- The **boost menu** is divided into **boost groups** (bG1 through bG6). The number of boost group displayed is determined by the number of set points selected in **nSP** (see section 4.3.7).
- The **boost groups** within the **boost menu** are edited by scrolling up or down to the desired boost group, pressing the **MODE** button to enter the boost group.
- Subsequently pressing the **SETUP/UP** or **BOOST/DOWN** arrows will scroll through the parameters in the **boost group**. The display will flash between the parameter and its current value.
- The value of the parameter is edited by pressing the **MODE** button. The value will be flashing to indicate it is ready to be edited. The value is then edited by pressing the **UP** or **DOWN** arrows until the desired value appears on the readout.
- Pressing **MODE** once the desired value is reached will save the parameter and exit back a level.
- Pressing and holding **MODE** for 2 seconds at any time will also save any **current editing** and return up one level in the menu structure.
- The **boost menu** is exited at any time by pressing the **MODE** button for 2 seconds or by scrolling to **End** and pressing **MODE** to exit. The e-Boost2 will display **EnD** as confirmation of exiting the **boost menu** and return to **live mode**.

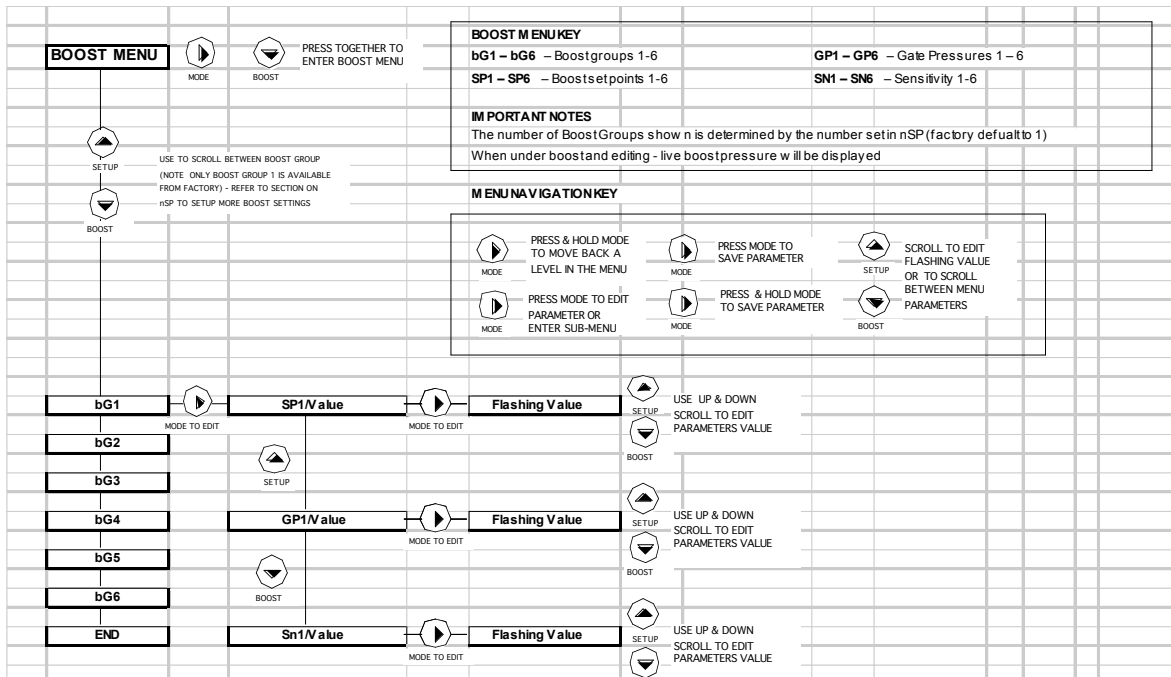

4.2.1 SP1 – SP6 - Boost Pressure Setting

The e-Boost2 can store up to six different boost pressure settings, we refer to the different boost pressure as **set points**, **SP1**, **SP2**, **SP3**, **SP4**, **SP5** and **SP6**. Each set point is located within a **boost group** **bG1**, **bG2**, **bG3**, **bG4**, **bG5** and **bG6**.

Boost pressure is determined by the boost set point value. The boost set point value can be set from 0 to 99 and is not directly related to an actual boost pressure. All set points are factory set to 0. Boost pressure is set by increasing or decreasing the value of each of the six boost set points. Increasing the boost set point will result in a higher boost pressure and vice versa.

The boost set point changes the effect that the e-Boost2 has on the pressure signal going to the waste gate actuator. A boost set point of 0 will have no effect on the actuator and therefore you will produce standard boost. A setting of 99 will result in the turbo producing as much boost as it can. Realistically the boost pressure that you are aiming for and its corresponding set point will be somewhere in the middle of this range.

When the e-Boost2 is powered up it will default to SP1, we recommend that you enter a boost pressure that is used most often in SP1.

The set points can be tuned live while editing this parameter under boost. When under boost pressure live boost will be displayed on the readout and the set point can be adjusted in real time to achieve your target boost pressure.

The e-Boost2-40 is capable of controlling boost pressures up to a maximum of 40psi (2.72bar or 272kPa).

The e-Boost2-60 is capable of controlling boost pressures up to a maximum of 60psi (2.72bar or 272kPa).

To change the boost pressure setting;

Step 1: The **BOOST Menu** is accessed by pressing and holding the **MODE** button and the **BOOST/DOWN** button simultaneously.

Step 2: Scroll to the appropriate **boost group** (e.g. bG1). Press **MODE** to enter the boost group. Pressing **MODE** again will enter the **Set Point** (eg SP1).

Step 3: Apply full load to the engine, in a high gear at full throttle. The **Live** boost pressure will be displayed on the readout. Note, the number that appears will be in bar, psi or kPa, depending on what has been set in the SCL readout parameter.

Step 4: To alter the boost pressure, increase or decrease the boost set point value by pressing the **SETUP/UP** or **BOOST/DOWN** arrow until the desired boost pressure appears on the readout. **Note:** The boost pressure readout will be **LIVE** readings/value if the vehicle is being tuned under boost. If the vehicle is not under boost, the readout will **NOT** be live boost but the set point value.

Step 5: Pressing **MODE** once the desired pressure is reached will save the new **set point** value and exit back a level.

Step 6: The **BOOST Menu** is exited at any time by pressing the **MODE** button for 2 seconds or by scrolling to **End** to exit. The e-Boost2 will display **End** as confirmation of exiting the **BOOST menu** and return to **live mode**.

Step 7: Check that the correct Air/Fuel ratio has been maintained once boost pressure is set.

Step 8: Repeat steps 1 through to 6 for SP2, SP3, SP4, SP5 and SP6.

Internal Waste gates - The table below is a **guideline only** to relate boost set point values to approximate boost pressures achieved when using an internal waste gate with a 7 psi (0.48 bar or 48 kPa) waste gate actuator. If your waste gate actuator has a higher minimum boost pressure, this table will **not** apply.

Boost Set Point	Approximate Boost Pressure achieved
30	0.68 bar / 10 psi / 68 kPa
40	1.02 bar / 15 psi / 102 kPa
50	1.29 bar / 19 psi / 129 kPa

External Waste gates - Please use caution! Reset all boost set point values to zero (0). Follow the steps 1-8 above to set boost pressures for each boost group starting at low set point values and working up to your desired boost pressure.

Note:

- The e-Boost2 cannot be used to obtain a boost pressure lower than the standard actuator setting
- The e-Boost2 cannot completely compensate for boost pressure drop at high RPM due to the turbocharger operating beyond its maximum efficiency range i.e. incorrect turbocharger sizing or excessive exhaust backpressure, or increases in boost pressure at high RPM due to inadequate waste gate flow capacity.
- The turbo system must maintain a steady base boost curve.
- The e-Boost2 cannot be used with external waste gates that are in a poor or worn condition.

4.2.2 GP1 – GP6 - Gate Pressure Setting

The Gate pressure function allows you to determine the pressure at which the waste gate begins to open. By optimising the gate pressure and keeping the waste gate closed as long as possible, your desired boost will be achieved faster and at lower RPM. Substantial gains in torque will be achieved.

Within each boost group there is a definable gate pressure; GP1, GP2, GP3, GP4, GP5 and GP6 that coincide with each boost group (bG1, bG2, bG3, bG4, bG5 and bG6). GP1 is active only when SP1 is active; GP2 is active only when SP2 is selected and so on.

The Gate pressure should only be set once your boost set points have been finalised – do not attempt to set the gate pressure first. The six gate pressures have been factory set to 3 psi (0.21bar or 21kpa). The objective when setting gate pressure is to maximise the gate pressure value without causing a boost spike. Increase the gate pressure until the boost pressure overshoots the desired setting. This boost spike is a result of the waste gate actuator being held closed too long. Reduce the gate pressure value until this boost spike is eliminated.

If the gate pressure is set beyond your actual boost pressure, the e-Boost2 will reach the gate pressure once and then revert to your actual boost pressure. Once the e-Boost2 registers a vacuum, the gate pressure function is reset and so on. This cycle is advantageous for certain applications where a momentary spike in boost is desired.

To edit the gate pressure, hold the **MODE** button and the **BOOST/DOWN** arrow button simultaneously to access the **BOOST menu**. Then scroll **UP** or **DOWN** to the desired boost group (bG1 – bG6), press the **MODE** button again to access the boost group. Scroll to the **gate pressure setting** (e.g. GP1) inside the boost group using the **UP** or **DOWN** arrows. Press the **MODE** button to enter the gate pressure setting. The gate pressure value will flash on the readout prompting it is ready to be edited. To change the value, press the up or down arrow. Pressing the **MODE** button will save the value and exit back one level. **Note:** Pressing and holding **MODE** for 2 seconds at any time will also save any **current editing** and return up one level in the menu structure.

4.2.3 Sn1 – Sn6 – Sensitivity Setting

Within each boost group menu the sensitivity of the e-boost2 can be adjusted for each group. There are six sensitivity settings that correspond to each boost group. The sensitivity can be set to a value between 0 and 99. The sensitivity is factory set to 20. Alternatively the sensitivity can be tuned live while editing this parameter under boost. The live boost pressure will be displayed on the readout and the sensitivity can be adjusted in real time. Refer to the table below for more detail.

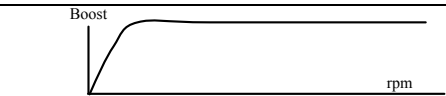
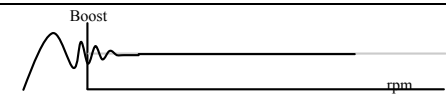
Sensitivity too low	<ul style="list-style-type: none"> - Achieves more boost in high gears - Takes longer to achieve boost set point - Boost drops off at higher RPM 	
Sensitivity correct	<ul style="list-style-type: none"> - Boost rises quickly and is steady 	
Sensitivity too high	<ul style="list-style-type: none"> - Boost pressure fluctuates, cycles or is not smooth - Boost pressure overshoots set point – rises too fast 	

Note: Actual boost pressure will increase slightly with an increase in sensitivity.

To edit the Sensitivity, hold the **MODE** button and the **BOOST/DOWN** arrow button simultaneously to access the **boost menu**. Then scroll **UP** or **DOWN** to the desired boost group (bG1 – bG6), press the **MODE** button again to access the boost group. Scroll to sensitivity (e.g. Sn1) inside the boost group using the **UP** or **DOWN** arrows. Press the **MODE** button to enter the sensitivity setting. The Sensitivity value will flash on the readout prompting it is ready to be changed. To change the value, press the up or down arrow. Pressing the **MODE** button will save the value and exit back one level. **Note:** Pressing and holding **MODE** for 2 seconds at any time will also save any **current editing** and return up one level in the menu structure

4.3 SETUP MENU – Basic Functions

- The **SETUP Menu** is accessed by pressing and holding the **MODE** button and the **SETUP/UP** arrow simultaneously.
- The setup parameters within the **SETUP Menu** are edited by scrolling up or down using the **UP** or **DOWN** arrows to the desired parameter, and pressing the **MODE** to enter the parameter.
- Subsequently pressing **UP** or **DOWN** arrows will scroll through the parameters in the sub menu if applicable.
- If a parameter is shown as solid then there is a sub menu that can be entered by pressing the **MODE** button. If the parameter does not have a sub menu then the parameter will flash between the parameter name and its current value or setting.
- Pressing the **MODE** button will edit a parameter that is flashing between its name and value or setting. Once **MODE** is pressed the value or setting will begin flashing indicating it is ready to edit and the **UP** and **DOWN** arrows can be used to adjust the value of the parameter until the desired value or setting appears on the readout.
- Pressing **MODE** once the desired value is reached will save and exit back a level.
- Pressing and holding **MODE** for 2 seconds at any time will also save any current editing and return up one level in the menu structure.
- The **SETUP Menu** is exited at any time by pressing the **MODE** button for 2 seconds or by scrolling to **End** to exit. The e-Boost2 will display **End** as confirmation of exiting the **SETUP Menu** and you will be returned to live mode.

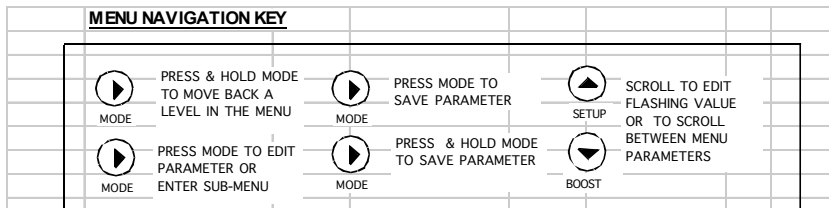

4.3.1 ObS - Over-Boost Shutdown VERY IMPORTANT!

In order to successfully program your e-Boost you MUST carefully follow this section
 Turbosmart recommends that this function is used in conjunction with another form of Over-boost protection such as fuel/ignition cut or over-boost valve. The over-boost function will not stop an over-boost scenario if there is a mechanical failure on the car that inhibits the e-Boost from controlling the wastegate or if electromagnetic interference due to incorrect wiring causes electrical interference to the e-Boost.

If the ObS is triggered the e-Boost2 begins to reduce the boost pressure to half of that set in the **ObS** parameter. Once this safe pressure is achieved the e-Boost will return to normal operation. **ObS** must be set to a level at least 2.2psi (0.15 bar or 15kPa) above the highest boost pressure. When the **ObS** is triggered **ObS** will flash on the display to indicate that your boost pressure has reached the over boost shut down value. **ObS** will continue to flash on the display until the pressure has been reduced to half that set in **ObS** and the unit has returned to normal operation. **ObS** will flash on the screen when triggered in live mode and when a set point is being edited under boost pressure but not inside the boost or setup menus until they are exited.

The **ObS** is factory set to 7 psi (0.48 bar or 48 kPa), so you must enter a figure in order for the e-Boost to produce more than a standard boost pressure. The purpose of this feature is to protect your engine against accidentally entering a boost set point value that is too high, preventing a dangerously high boost pressure. Extreme care should be taken when setting this parameter. Turbosmart recommends that you seek advice from an appropriately qualified technician with regard to the **ObS** setting.

To edit the over boost shutdown (**ObS**), hold the **MODE** button and the **SETUP/UP** arrow simultaneously to access the **SETUP Menu**. Scroll **UP** to **ObS**; press the **MODE** button again to access **ObS**. The **ObS** value will flash on the readout prompting it is ready to be edited. To change the value, press the **UP** or **DOWN** arrow. Pressing the **MODE** button will save the value and exit back one level. **Note:** Pressing and holding **MODE** for 2 seconds at any time while inside the **ObS** will also save any current editing and return up one level in the menu structure. To exit **SETUP Menu** and return to **live mode** press and hold **MODE** for two seconds.

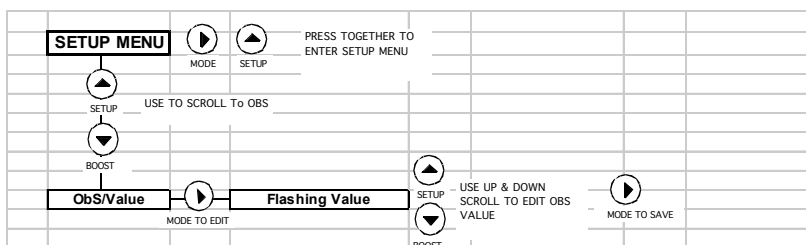

4.3.2 CYL – Cylinder Selection

If you have connected the yellow RPM wire to an RPM signal from your ECU or negative terminal of an ignition coil you will need to input the number of cylinders / rotors in order to configure the RPM signal correctly i.e. the number of pulses per revolution being picked up from the RPM output of the ECU. The number of cylinders available is between 1 and 16. The RPM input can accept a square wave signal between 3.5 and 12V. Twin rotor and triple rotor engines can be configured as 4 and 6 cylinders respectively.

To edit the Cylinder Selection (CYL), hold the **MODE** button and the **SETUP/UP** arrow simultaneously to access the **SETUP Menu**. Scroll to CYL; press the **MODE** button again to access CYL. The CYL value will flash on the readout prompting it is ready to be edited. To change the value, press the **UP** or **DOWN** arrow. Pressing the **MODE** button will save the value and exit back one level. **Note:** Pressing and holding **MODE** for 2 seconds at any time while inside the CYL will also save any **current editing** and return up one level in the menu structure. To exit **SETUP Menu** and return to **live mode** hold **MODE** for two seconds.

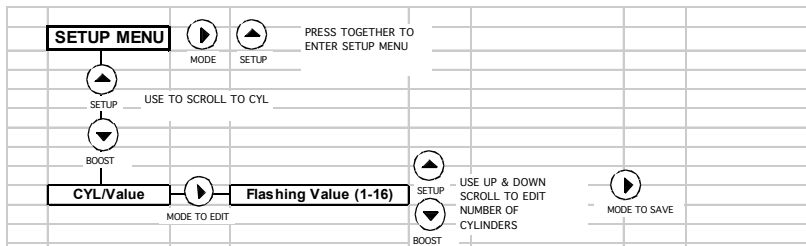

4.3.3 SCL – Pressure Unit Scale for Main Readout (PSI/KPA/bAr)

The e-Boost2 readout can be configured in either bar, psi or kPa, the default setting is in psi. This allows you to tailor the readout to suit your own preference. Note that when the psi scale is selected and the e-Boost2 is under vacuum conditions the display will read in inches of Mercury (inHg) not negative psi.

To edit the e-Boost2 Readout (SCL), hold the **MODE** button and the **SETUP/UP** arrow simultaneously to access the **SETUP Menu**. Scroll down to SCL; press the **MODE** button again to access SCL. Scroll to the desired readout format. Pressing the **MODE** button will save the desired readout format and exit back one level. **Note:** Pressing and holding **MODE** for 2 seconds at any time while inside SCL will also save any **current editing** and return up one level in the menu structure. To exit **SETUP Menu** and return to **live mode** press and hold **MODE** for two seconds.

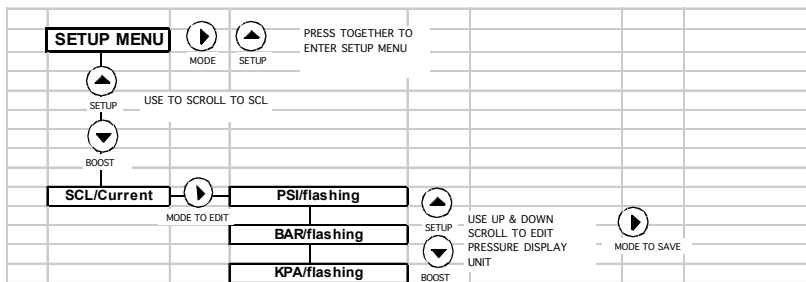

4.3.4 LE1/LE2 – Shift/Warning LEDS

The e-boost2 has 2 LED outputs that can be used as shift lights or boost level warning lights. These LED outputs can be configured to turn on and off at any boost pressure or engine RPM. Within the LE1/LE2 menu there are 5 parameters bOn (Boost pressure on), bOF (Boost pressure off), rOn (RPM on), rOF (RPM off) and rFL (RPM flashing).

Between the on and off values the LED will be illuminated. If the bOF or rOF is set to zero there will be no off and the LED will remain illuminated until boost or RPM drops below the bOn or rOn value.

You can also set a flashing warning RPM value rFL (RPM flashing) at which the led will flash until rOn is reached. Once rOn is reached the LED will turn on solid. rFL must be set to an RPM less than rOn. Setting rFL to zero will disable the flashing output.

Boost values are entered in the units currently selected for boost pressure display. RPM values are entered as RPM x 100 e.g. if 5000 RPM is the desired setting then input 050. If using a boost setting, RPM values should be set to zero to turn them off. If using a RPM setting the boost parameters should be set to zero to turn them off.

The four wires associated with these two outputs are wired into a 4 pin plug located beside the main harness 8 pin plug. A single or double LED accessory kit is available from Turbosmart that plugs directly into the eboost2 LED output with no additional wiring necessary.

If rOn, rOF, bOn and bOF values are entered on 1 LED, the LED will illuminate only when the RPM set points have been reached. The boost values are redundant.

To edit the **LE1** & **LE2** parameters, hold the **MODE** button and the **SETUP/UP** arrow simultaneously to access the **SETUP Menu**. Scroll down to the appropriate setup parameter (**LE1/LE2**); press the **MODE** button again to access **LE1/LE2**. Scroll down to the desired parameter. Pressing **MODE** will access the parameter; the value will begin to flash prompting it is now ready to be changed using the **UP** or **DOWN** arrows. Pressing the **MODE** button will save the desired value and exit back one level. **Note:** Pressing and holding **MODE** for 2 seconds at any time while inside the **LE1/LE2** will also save any **current editing** and return up one level in the menu structure. To exit **SETUP Menu** and return to **live mode** press and hold **MODE** for two seconds.

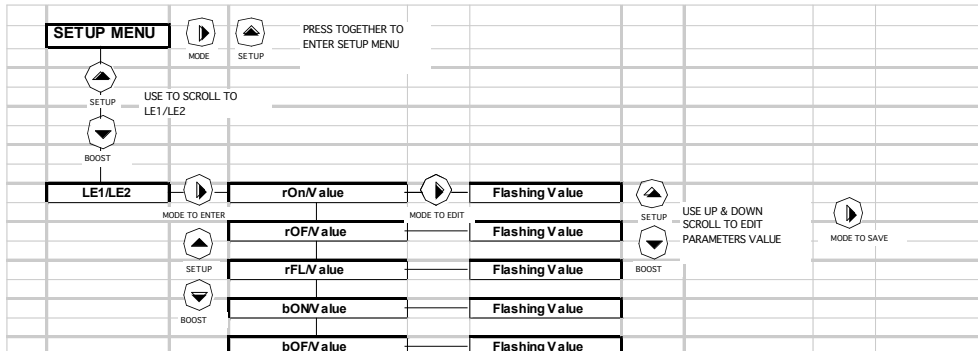

4.3.5 bGr - Bar Graph

The e-Boost2 bar graph can be configured to indicate a pressure between zero and full scale (40 psi or 60 psi). The bar graph has ten segments, seven blue segments and three red segments. When seven segments are illuminated the pressure that has been programmed in this parameter has been reached. The bar graph is factory set to 15 psi. The desired display pressure can be adjusted to your preference and is typically set to your maximum boost level.

To edit the Bar Graph (**bGr**), hold the **MODE** button and the **SETUP/UP** arrow simultaneously to access the **SETUP Menu**. Scroll down to **bGr**; press the **MODE** button again to access **bGr**. Scroll to the desired value using the **UP** or **DOWN** arrows. Pressing the **MODE** button will save the desired value and exit back one level. **Note:** Pressing and holding **MODE** for 2 seconds at any time while inside the **bGr** will also save any **current editing** and return up one level in the menu structure. To exit **SETUP Menu** and return to **live mode** press and hold **MODE** for two seconds.

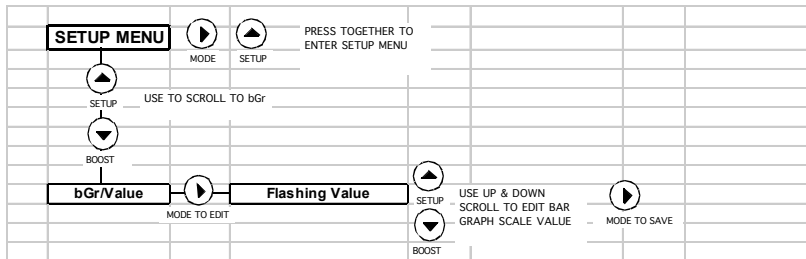

4.3.6 AL - Audible Alarm

The e-Boost2 has an audible alarm function that sounds the internal buzzer once a certain boost pressure or RPM is achieved. The audible alarm is factory set to 15 psi (1 bar or 100 kPa) but can be programmed for any boost pressure or RPM. Within the **AL** parameter there are four options **bOn**, **bOF**, **rOn** and **rOF**.

The boost setting on (**bOn**) and off (**bOF**) values are entered in the units that are currently selected for display. Between the **bOn** and **bOF** values the buzzer will be activated.

The RPM setting on (**rOn**), and off (**rOF**) are entered as RPM x 100 e.g. if 5000 RPM is the desired setting then input 050. Between the **rOn** and **rOF** values the buzzer circuit will be closed.

If the **bOF** or **rOF** is set to zero there will be no off and the buzzer circuit will remain closed until boost or RPM drops below the **rOn** or **bOn** value. If using a boost setting RPM values should be set to zero to turn off or visa versa. Setting these parameters to zero will disable them as parameters.

If **rOn**, **rOF**, **bOn** and **bOF** values are entered, the alarm will sound when either the boost or the RPM value is reached and will turn off when the boost or RPM drops below the set point or both values reach there respective **bOF** and **rOF** values.

To edit the Audible Alarm (**AL**), hold the **MODE** button and the **SETUP/UP** arrow simultaneously to access the **SETUP Menu**. Scroll down to **AL**; press the **MODE** button again to access **AL**. Scroll to the desired parameter (**rOn**, **rOF**, **bOn**, **bOF**). Pressing **MODE** will access the parameter. The **RPM** or boost pressure will flash on the readout depending on what was selected. The value can now be changed using the **UP** or **DOWN** arrows. Pressing the **MODE** button will save the desired parameter and exit back one level. **Note:** Pressing and holding **MODE** for 2 seconds at any time while inside the **AL** will also save any **current editing** and return up one level in the menu structure. To exit **MODE** and return to **live mode** press and hold **MODE** for two seconds.

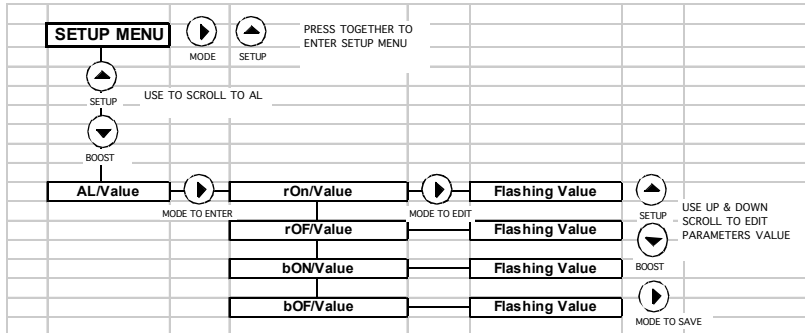

4.3.7 nSP – Number of Set Points

The e-boost2 can be configured for up to six different boost groups (BG1-6). Setting nSP to a value from 1-6 will then enable that number of boost groups (and their associated set point, gate pressure and sensitivity) in the boost menu and live mode. For example if you set nSP to 4, in the boost menu there will appear 4 boost groups (bG1-4). The default number of set points is factory set at 1.

To edit the number of set points (nSP), hold the **MODE** button and the **SETUP/UP** arrow simultaneously to access the **SETUP Menu**. Scroll down to **nSP**; press the **MODE** button again to access **nSP**. The parameter will flash on the readout; the value can now be changed using the **UP** or **DOWN** arrows. Pressing the **MODE** button will save the desired parameter and exit back one level. **Note:** Pressing and holding **MODE** for 2 seconds at any time while inside the **nSP** will also save any **current editing** and return up one level in the menu structure. To exit **SETUP Menu** and return to **live mode** press and hold **MODE** for two seconds.

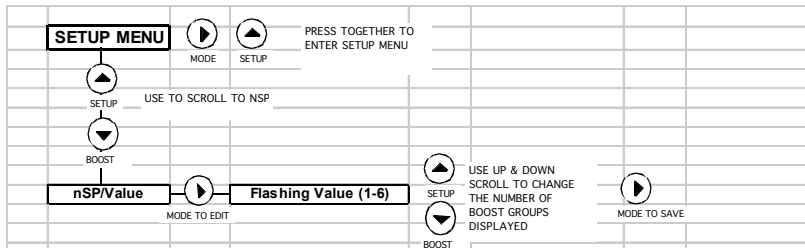

4.3.8 rES – Factory Reset

This function performs a factory reset and returns all the settings back to factory default.

To restore the settings back to factory default (rES), hold the **MODE** button and the **SETUP/UP** arrow simultaneously to access the **SETUP Menu**. Scroll down to **rES**; press the **MODE** button again to access **rES**. Scroll to the desired selection (**yES/nO**) using the **UP** or **DOWN** arrows. Pressing the **MODE** button will save the selection and exit back one level. To exit **SETUP Menu** and return to **live mode** press and hold **MODE** for two seconds.

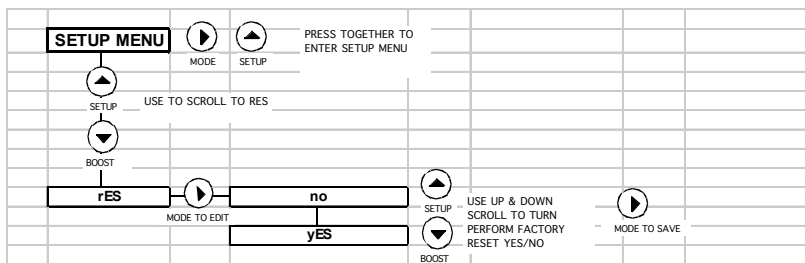

4.3.9 ZEr – Re-Zero Display

The e-Boost2 is factory calibrated to read zero at standard atmospheric pressure and temperature. The e-Boost2 is altitude compensated however a large change in temperature can cause the display to read slightly above or below zero even when there is zero pressure applied to the e-Boost2. This function allows you to re-zero the e-Boost2 if your display reads up to 1 psi (or equivalent in on other units if selected) above or below the original zero point. **IMPORTANT! Before using the zero function ensure there is no boost or vacuum pressure or trapped pressure in the e-boost hose before re-calibration.** This function only allows a reading to be corrected up to plus or minus 1 psi. This gives some safety against un-intended re-calibration while under large boost or vacuum pressures.

To re-calibrate the zero point firstly ensure there is no boost or vacuum pressure being applied to the e-Boost2. Hold the **MODE** button and the **SETUP/UP** arrow simultaneously to access the **SETUP Menu**. Scroll down to **ZEr**; to zero press the **MODE** once and the display will now read zero and your re-calibration is complete. To exit **SETUP Menu** and return to **live mode** press and hold **MODE** for two seconds.

5.0 e-Boost2 - ADVANCED OPERATION

5.1 AU –Auxiliary Output

The e-Boost2 has an auxiliary output function designed to control an auxiliary device once a certain boost pressure or RPM value is reached i.e. water spray, water injection, warning light or nitrous controller. This circuit can be used to control a **resistor type automotive relay** with a maximum current draw of 2 amps.

There are four options bOn, bOF, rOn and rOF. The boost setting on (bOn) and off (bOF) value will be entered in the units that are currently selected for display. Between the bOn and bOF values the auxiliary output circuit will be closed and therefore will switch the relay on.

The RPM setting on (rOn), and off (rOF) are entered as RPM x 100 e.g. if 5000 RPM is the desired setting the user will input 050. Between the rOn and rOF values the auxiliary output circuit will be closed.

If the bOF or rOF is set to zero there will be no off and the circuit will remain closed until boost or RPM drops below the rOn or bOn value. If using a boost setting only to switch the relay the RPM parameter values should be set to zero to turn off or vice versa.

If using the auxiliary circuit as a nitrous controller, you can enter all four user definable parameters bOn, bOF, rOn, and rOF. The auxiliary circuit will be closed when boost and RPM fall with the window created by these four parameters. That is when boost pressure is between bOn and bOF **AND** when RPM is between rOn and rOF.

To edit the Auxiliary (AU), hold the **MODE** button and the **SETUP/UP** arrow simultaneously to access the **SETUP Menu**. Scroll down to **AU**; press the **MODE** button again to access **AU**. Scroll to the desired parameter (**rON,rOF,bON,bOF**). Pressing **MODE** will access the parameter. The RPM or boost pressure will flash on the readout depending on what was selected. The value can now be changed using the **UP** or **DOWN** arrows. Pressing the **MODE** button will save the desired parameter and exit back one level. **Note:** Pressing and holding **MODE** for 2 seconds at any time while inside the **AU** will also save any **current editing** and return up one level in the menu structure. To exit **SETUP Menu** and return to **live mode** press and hold **MODE** for two seconds.

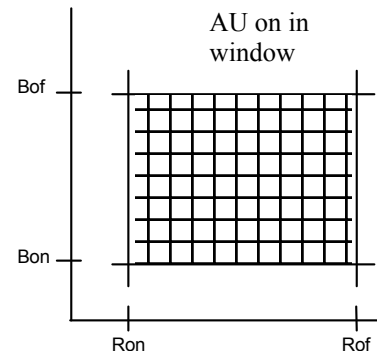
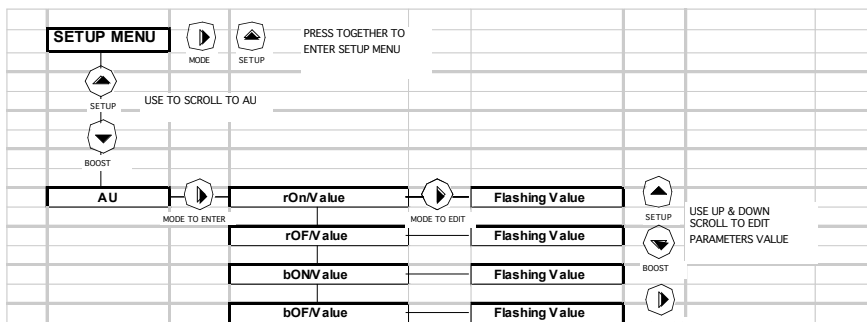

5.2 dS1 –dS6 – Delayed Switching

This function is for use with set point switch logics ISP/ESP/SSA/SSB and is designed to create a delay between set point switching and activation. The time delay will be between when a subsequent set point is switched and when it actually changes i.e. the current set point will continue functioning until the time delay has elapsed. dS1 in boost group 1 applies to the time delay when switching to SP1, dS2 in boost group 2 applies to the time delay when switching to SP2 and so on. To use time delay between set point switching and activation, dS must be ON. In the SETUP Parameter Menu you can activate or de-activate this function. If this function is de-activated all menus relating to the time delay are hidden from the Boost Menu i.e. dS1 – dS6 in respective boost group. Once dS is activated in the SETUP Parameter Menu, you can enter the delay time in the Boost Group.

To change whether the Delay Switching (dS) function is on or off, hold the **MODE** button and the **SETUP/UP** arrow simultaneously to access the **SETUP Menu**. Scroll down to **dS**; press the **MODE** button again to access **dS**. Scroll to the desired parameter (**ON/OFF**). Pressing the **MODE** button will save the desired setting and exit back one level. **Note:** Pressing and holding **MODE** for 2 seconds at any time while inside the **dS** will also save any **current editing** and return up one level in the menu structure. To exit **SETUP Menu** and return to **live mode** press and hold **MODE** for two seconds.

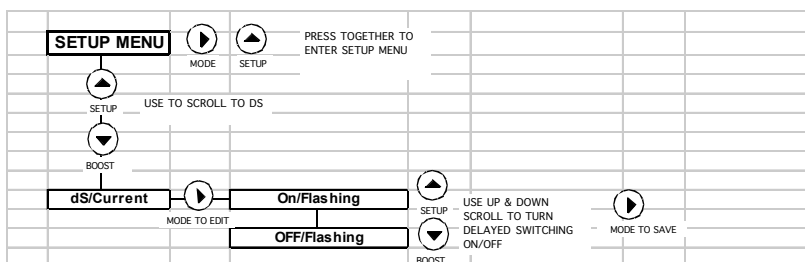

Once dS has been turned on in the SETUP menu the parameter dS1-6 will each in each active boost group.

To edit the delayed switching value (e.g. dS1 in bG1); assuming dS is set to on in the setup menu. Hold the **MODE** button and the **BOOST/DOWN** arrow simultaneously to access the **Boost Menu**. Then scroll up or down to the desired boost group (bG1 – bG6), press the **MODE** button again to access the boost group. Scroll to **Delay Switching (dS)** inside the boost group using the **UP** or **DOWN** arrow. Press the **MODE** button to enter the dS parameter. The delayed switching value will flash on the readout prompting it is ready to be edited. To change the value, press the **UP** or **DOWN** arrows and scroll to the desired value. Note these values are

set in tenths of a second. Pressing the **MODE** button will save the value and exit back one level. **Note:** Pressing and holding **MODE** for 2 seconds at any time will also save any **current editing** and return up one level in the menu structure.

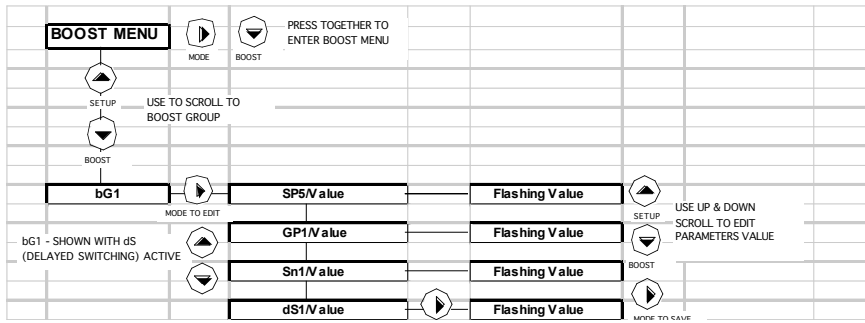

Note: Activating SSC/SSD and SSE also brings up the dS parameter in the boost group. Refer to section 5.6 for further details on the set point switching logic and what this parameter applies to.

5.3 Pin –Password Protection

The user or workshop can set a 3 digit password that will lock the boost menu, Obs, SL, rSP, COR, dS, nSP, and CYL parameters for editing. The default code is 000 set from the factory. If the code has not been changed then the unit will be fully accessible and everything will be available for editing. As soon a different value is entered under the Pin parameter in the setup menu this will be the new password.

Once a password has been set under PIN in the setup menu pressing mode and down to access the boost menu will bring up a 3 digit prompt (triple zeros) where a PIN must be entered correctly to enter the boost group and unlock the unit.

Once a password has been configured the Obs, CYL, SL, rSP, COR, dS, nSP, in the setup menu will be masked and not available for editing. To unmask these parameters go to the Pin parameter and enter the current password to unlock the setup parameters for editing. Alternatively enter the correct PIN in the boost group prompt and the entire unit will be unlocked until the PIN is re-entered in the PIN parameter to re-lock the unit.

Applying the factory reset will reset the code and reset all stored values to the factory defaults. This function enables workshops or tuners to lock their setup against tampering. Returning the PIN to 000 will de-activate the password protection.

To edit the Password (Pin), hold the **MODE** button and the **SETUP/UP** arrow simultaneously to access the **SETUP Menu**. Scroll down to Pin; press the **MODE** button again to access Pin. The default 000 will appear on the readout; The first digit will be flashing. Using the scroll arrows, scroll to the desired first digit. Pressing the **MODE** button will move to the second digit, again scroll using up and down to change the digit. Pressing the **MODE** button again will move to the third digit, again scroll using up and down to change the digit. Pressing the **MODE** button after all three digits are entered will save the desired Pin and exit back one level. The unit will now be locked and the PIN has to be re-entered at the boost group prompt or the PIN parameter in the setup menu to unlock the unit. Follow the same procedure to enter the PIN when prompted if trying to access the boost group when the unit is locked.

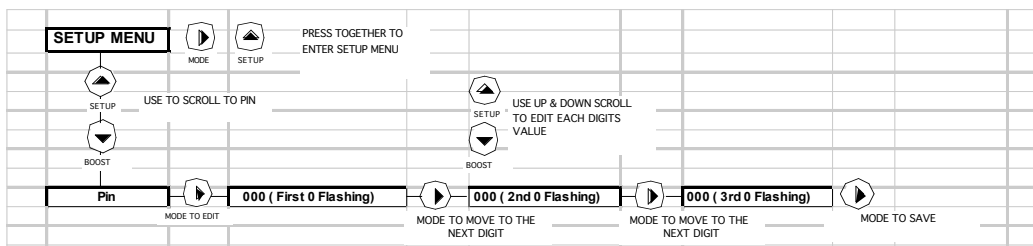

5.4 COR – Offset Correction Function

The offset correction function is designed to compensate a drop off in boost at high RPM that may occur when increasing your boost beyond the efficient operational limits of your turbo size.

When the Offset Correction function is turned on **FAC**, **rp1** and **rp2** will appear in each boost group. In the rP1 parameter enter the RPM at which you notice a drop in the boost pressure. This value is entered as RPM x100. Set the rP2 to your maximum engine RPM. Then enter a correction factor between 0-100 to apply a linear correction to your boost curve. Note this is the maximum percentage by which you can increase your set point i.e. you can only double your current set point at maximum RPM.

For example if you notice your boost curving dropping at 5000 RPM you would enter 050 in the rp1 parameter. If your maximum RPM that you would rev your engine to is 9000 then enter 090 in rp2. If you notice your boost is dropping by 25% over this rev range then try to increasing your offset by 25% to compensate for this by entering 25 in FAC.

Once completed check your new boost curve to see if you have corrected boost drop off. Adjust this factor as appropriate but caution should be exercised when choosing a factor and you should start with a low value and work you way up. Tuning should be performed on a dynamometer by an appropriately qualified technician. Again this function is designed to compensate for the inefficiencies introduced when increasing your boost beyond the efficient operational limits of your turbo size, the e-Boost2 may not be able to completely compensate for incorrect turbo sizing.

Note: This function is not available with rSP (RPM set point mapping) or SSE (time based set point mapping). Activating this function with rSp turned on will turn rSp off. If SSE is active then this function cannot be turned on and if SSE is turned on when rSP is already active then rSP will be turned off.

To turn the Offset Correction Factor (COR) on or off, hold the **MODE** button and the **SETUP/UP** arrow simultaneously to access the **SETUP Menu**. Scroll down to **COR**; press the **MODE** button again to access **COR**. Scroll to the desired parameter (**ON/OFF**). Pressing **MODE** will access the parameter. The parameter will flash on the readout; the value can now be changed. Pressing the **MODE** button will save the desired parameter and exit back one level. **Note:** Pressing and holding **MODE** for 2 seconds at any time while inside the **COR** will save any **current editing** and return up one level in the menu structure. To exit **SETUP Menu** and return to **live mode** hold **MODE** for two seconds.

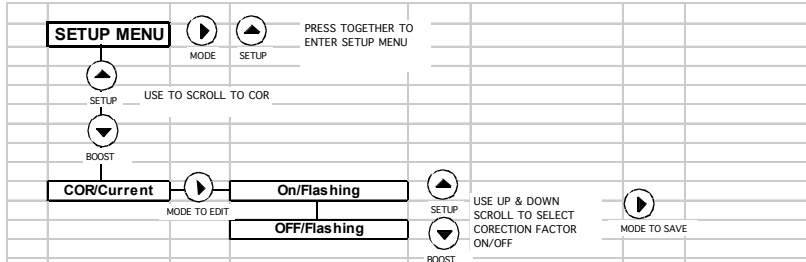

Once the **COR** function is activated **FAC**, **rP1** and **rP2** will appear in each boost group and values can now be entered in the boost group for these parameters following the general editing procedure for the boost group.

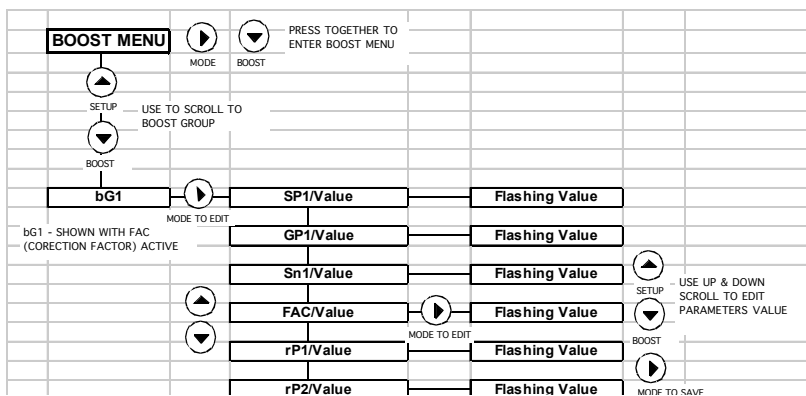

EXAMPLE: BOOST VS RPM CURVES

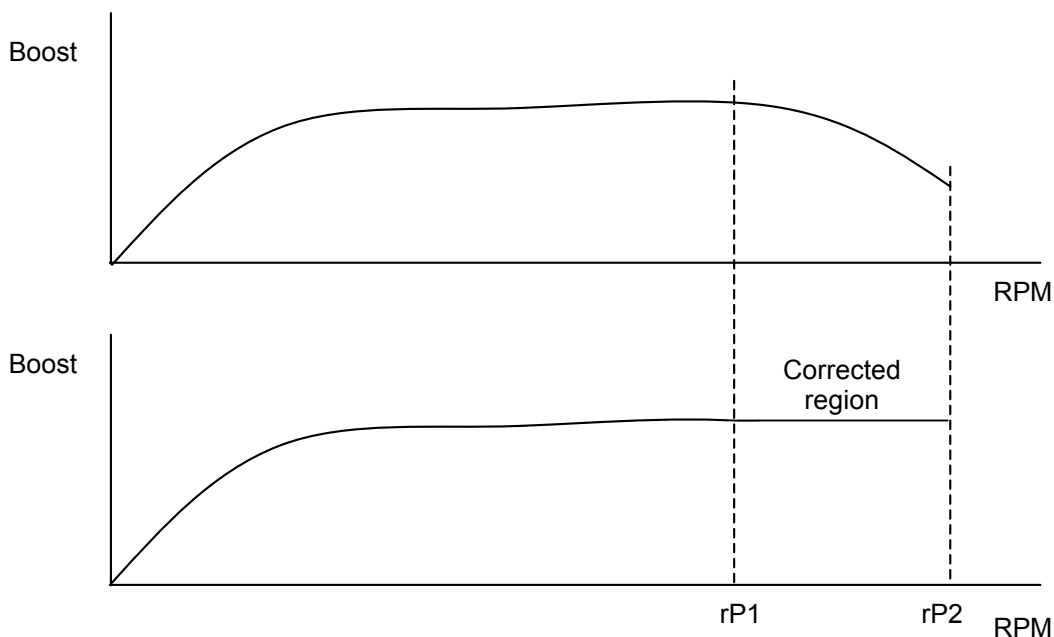

5.5 rSP – RPM Based Set Point Mapping

RPM based set point mapping (**rSP**) is a function that allows you to map your boost curve against RPM. You can enter set point (SP) values against RPM values so you can tailor your boost curve. The RPM values are mapped in increments of 500 or 1000 RPM depending on the maximum RPM selected. RPM is displayed on the readout as RPM x100 eg 005 (5 x 100RPM) is 500 RPM. At each increment the desired offset which in turn gives you a boost pressure can be defined. When this function is turned on the RPM points 005, 010, 015, 020 through to 190, 195, 200 will appear in each boost group. Entering a value in the Boost Set Point (SP) parameter of the boost group will paste that value through all RPM points. This gives a starting point to adjust from.

When activating this function 3 options are available **off**, **10** and **20**. Selecting 100 will give a max RPM of 10000 with 500 RPM increments and selecting 200 will give a max RPM of 20000 and 1000 RPM increments. You could use this function to smooth out dips in your normal boost curve at certain RPM by enter higher set point values for these RPM. Note this function is available for use with ISP, ESP and SSA-SSC. This function is cannot be turned on if SSD or SSE is on and if SSD or SSE is activated with rSP already then rSP will be turned off. rSP also cannot be used at the same time as COR (turning rSP on with COR already on will turn off COR). Gate pressure can be used with this function and will override rpm set point values until the gate pressure is reached.

To edit the RPM based set point mapping (rSP), hold the **MODE** button and the **SETUP/UP** arrow simultaneously to access the **SETUP Menu**. Scroll down to rSP; press the **MODE** button again to access **rSP**. Scroll to the desired setting (**Off/10/20**). Pressing the **MODE** button will save the desired parameter and exit back one level. **Note: Pressing and holding MODE** for 2 seconds at any time while inside the rSP will also save any **current editing** and return up one level in the menu structure. To exit **SETUP Menu** and return to **live mode** press and hold **MODE** for two seconds.

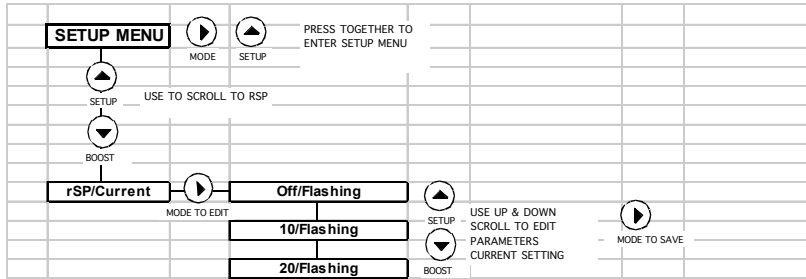

To edit the RPM points enter the **BOOST Menu** and enter boost group. Scroll up until you reach the first data point the display with flash rSP then toggle between the data point and its current value. For example the first data point is 005 (500 RPM) followed by its current set point value. Press **MODE** to edit the data point and scroll **UP** or **DOWN** to your desired set point value. Pressing **MODE** will save the RPM point. Press **UP** to move on to the next point.

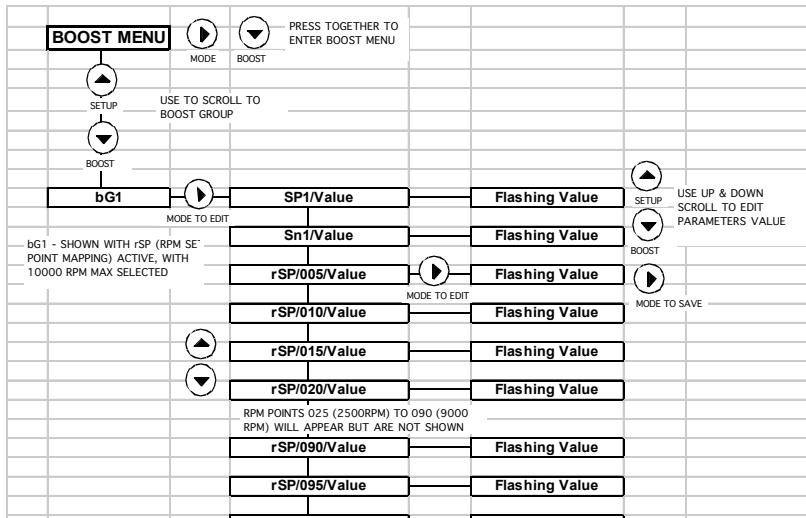

Below is an example of the set point vs. RPM mapping. **WARNING THE BELOW GRAPH IS AN EXAMPLE ONLY. THESE VALUES SHOULD BE DETERMINED BY AN APPROPRIATELY QUALIFIED TECHNICIAN.**

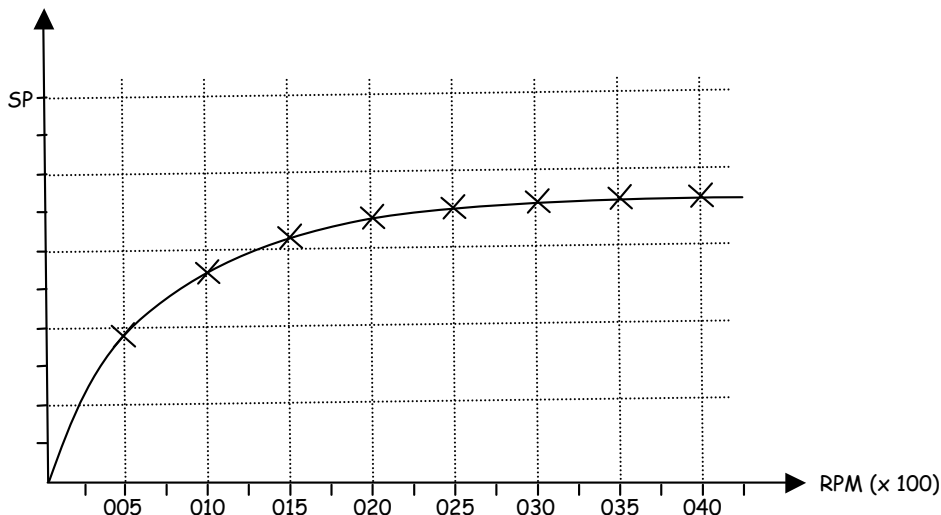

5.6 SEr – serial number display

The serial number of your e-Boost2 unit can be displayed on the screen. This can be useful for technical support. The number will scroll through 6 numbers.

6.0 Switch Logic (SL)

The e-Boost is factory set for internal set point switching where the up and down arrows are used to switch set point, but can be configured for external set point switching using externally mounted switches to trigger inputs to ground in conjunction with a switch logic (BOD to SSE).

The e-boost2 switch logic is configured from the SL menu within the SETUP parameter menu. The SL parameter allows you to toggle between ISP, ESP, BOD and the sequential switching functions SSA, SSB, SSC, SSD and SSE. Within the setup menu the SL parameter will be flashing between SL and the currently selected switch logic. Eg factory setting is SL/ISP.

IMPORTANT! Before setting up your boost group switching you should know what boost pressure you achieve with each set-point setting in its relevant boost group. For example if you want to run four different boost levels you should set up four groups and test what each of your boost levels are before setting up switching between each boost group.

The delayed switching function in the boost group menu will function with ISP, ESP, SSA & SSB if delayed switching (dS) is activated. dS will be automatically active for SSC, SSD and SSE see below for further details.

To edit the switch logic (SL), hold the **MODE** button and the **SETUP/UP** arrow simultaneously to access the **SETUP Menu**. Scroll down to **SL**; press the **MODE** button again to access **SL**. Scroll to the desired parameter (**ISP/ESP/BOD/SSA/SSB/SSC/SSD/SSE**). Pressing the **MODE** button will save the desired parameter and exit back one level. **Note:** Pressing and holding **MODE** for 2 seconds at any time while inside the SL will also save any **current editing** and return up one level in the menu structure. To exit **SETUP Menu** and return to **live mode** press and hold **MODE** for two seconds.

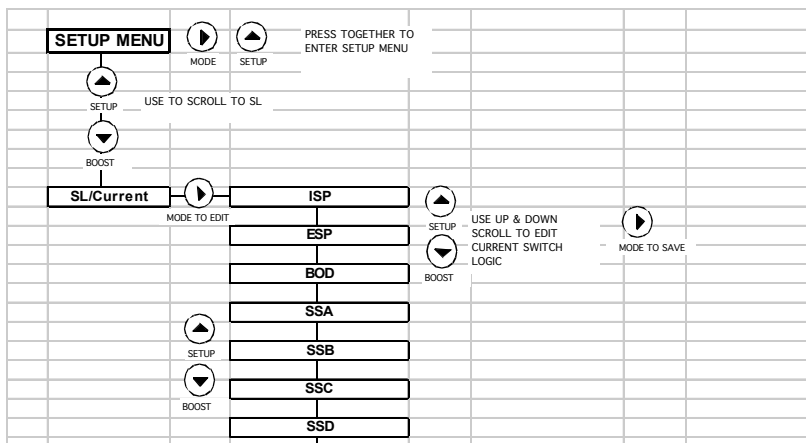

6.1 – ISP – Internal switch points

The e-Boost is factory set for internal set point switching where the up and down arrows are used to switch the boost set points.

6.2 – ESP – External switch points

Up to four boost groups can be selected directly by externally by grounding or earthing the green and or orange wires from the e-Boost2 loom to the chassis. The set points are switched externally by earthing the appropriate wire corresponding with the set point you wish to select, see the table below for detail.

Active set point	Green wire	Orange Wire
Set point 1	Not connected	Not connected
Set point 2	Earthed	Not connected
Set point 3	Not connected	Earthed
Set point 4	Earthed	Earthed

6.3 – BOD – Boost on demand

Allows you to select a boost set point for an inputted value of time before returning to the previous set point. When the BOD function is activated within the switch logic menu, an additional sub-menu will appear in bG2 and bG3 of the boost menu called bd2 and bd3. bd2 is the value of time in seconds, bG2 will be selected before returning to the previous set point. Bd3 is the value of time in seconds, bG3 will be selected before returning to the previous set point.

- Earthing the green wire will trigger bG2 for the inputted value of time
- Earthing the orange wire will trigger bG3 for the inputted value of time
- Maximum time that a boost group can be selected is 99 seconds
- The boost and setup buttons on the e-Boost2 unit will function as normal in ISP mode.

6.4 – SSA – Sequential switching function A

Allows you to sequentially switch between different boost settings. This switch logic could be applied in a situation where you want to have a different boost level in each gear.

- Earthing the green wire with a switch will scroll up a single set point.
- Earthing the green wire again will switch up another single set point.
- The maximum number of set points that can be switch up to is determined by nSP in the setup menu.
- Once the maximum set point is reached through switching further switching not increase the set point any higher.
- Earthing orange wire with a switch will reset and return to SP1.

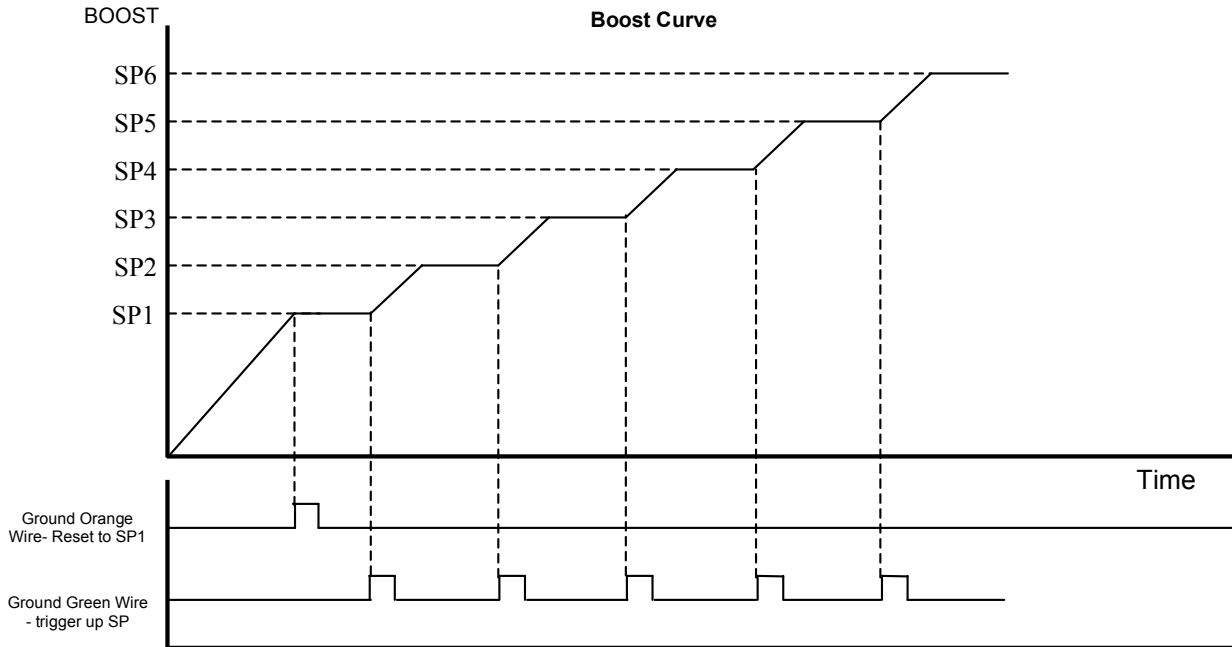

6.5 – SSB - Sequential switching function B

Sequential Switching Function B allows you to sequentially switch up and down between different boost settings using external switches. This switch logic could be applied in a situation where you want to have a different boost levels in each gear.

- Earthing the green wire with a switch will switch up a single set point.
- Earthing the green wire again will switch up another single set point.
- The maximum number of set points that can be switch up to is determined by nSP in the setup menu.
- Once the maximum set point is reached through switching (note: will only switch up to SP6).
- Earthing orange with a switch will wire switch down a single set point.
- Earthing the orange wire again will down another set point. (note: will only switch down to SP1).

Example Boost Curve

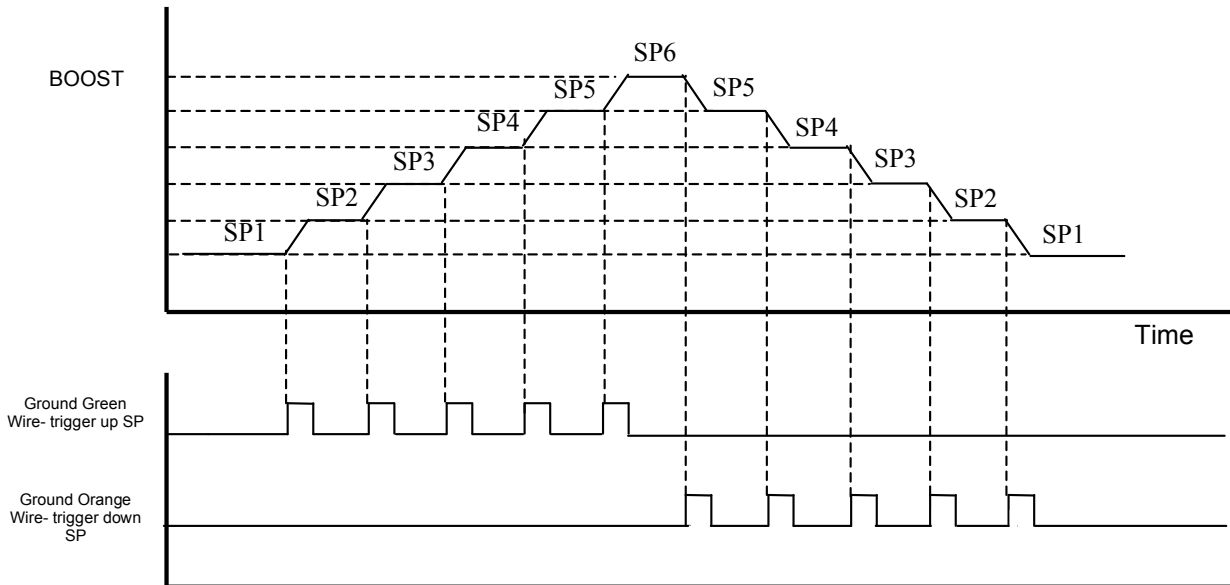

6.6 – SSC - Sequential switching function C

Timed sequential switching function C allows the boost groups/set-points to be active then switched at predetermined time intervals. This switch logic could be applied in a drag racing situation where you want to switch boost levels at known time intervals within your elapsed time (ET).

- With SSC active dS1-dS6 will appear in each boost group.
- These time intervals can be entered as the amount of time you want each set point to be active before switching to the next set point.
- Time delays are in increments of 1/10th of a second, with the maximum allowable being 99 seconds.
- dS1 will refer to the amount of time SP1 is active before switching to SP2, dS2 to the amount of time SP2 is active before switching to SP3 and so on.
- Earthing the orange wire with a switch will reset the timer and switch to SP1/BG1.
- Earthing the green wire will start the timer and the time interval dS1 during which SP1 will be active.
- At the end of the time interval dS1 the unit will switch to SP2 and SP2 will be active for the time interval dS2.
- The same procedure will happen for all active set points (determined by the nSP parameter in the setup menu)
- Once the last time interval has ended the unit will continue to operate at the final set point.
- Note to skip a set point/boost group set the dS parameter for that group to equal zero.
- This is a solely time based switching method and is not dependant on switching except for the reset to SP1 (earthing the orange wire) and a GO (earthing the green wire) which will start the timer.

To edit the delayed switching value (e.g. dS1 in bG1); assuming SSC is active in the setup menu under the SL parameter. Hold the **MODE** button and the **BOOST/DOWN** arrow simultaneously to access the **Boost Menu**. Then scroll up or down to the desired boost group (bG1 – bG6), press the **MODE** button again to access the boost group. Scroll to **Delay Switching (dS)** inside the boost group using the **UP** or **DOWN** arrow. Press the **MODE** button to enter the **dS** parameter. The delayed switching value will flash on the readout prompting it is ready to be edited. To change the value, press the **UP** or **DOWN** arrow and scroll to the desired value. Note these values are set in tenths of a second. Pressing the **MODE** button will save the value and exit back one level.

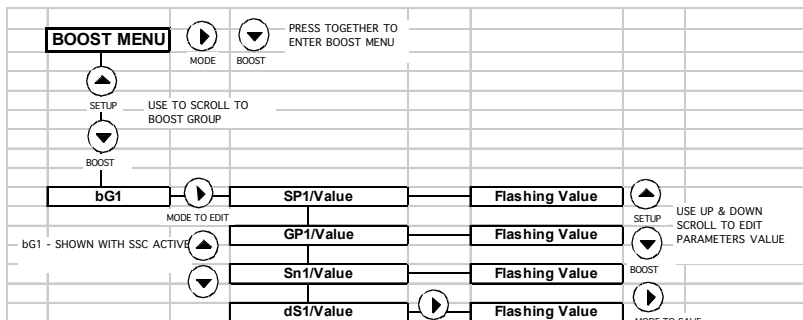

Example Boost Curve

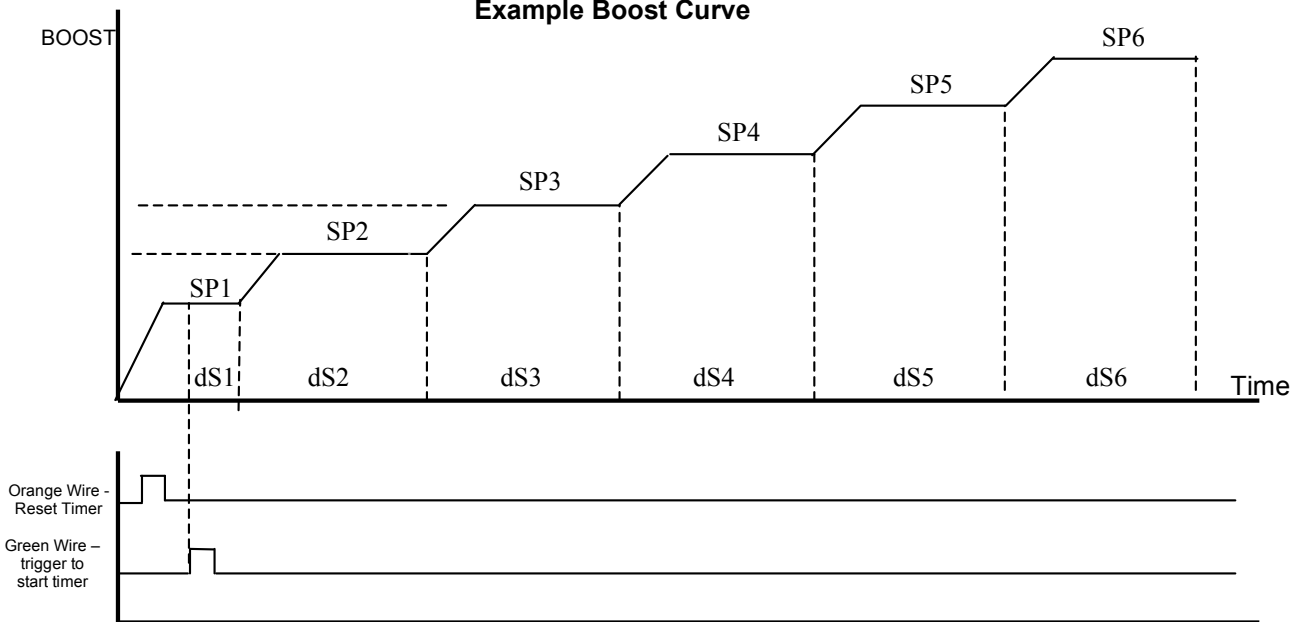

6.7 – SSD - Sequential switching function D

Sequential switching function D is an advanced boost level switching function where you can configure a time delay to give either a drop in boost or a spike between switching boost levels. For example in a drag racing application you may want lower your boost during launch to maintain traction and spike your boost during gear changes to compensate for a drop in RPM.

EXAMPLE 1. BOOST DIPPING BETWEEN BOOST LEVEL SWITCHING

- Earthing the green wire will scroll up through set points starting at SP1 up to SP6 one at a time.
- Earthing the orange wire will reset and return to SP1 and dS1 (launch time delay)
- Activating SSD will display dS1-6 in their respective boost groups.
- These time intervals (dS1-6) can be used to give a dip in boost or spike in boost during the time delay.
- To create a dip in boost set the gate pressure to zero of the boost group that you are switching to. For example to dip the boost in the launch sequence set GP1 to zero as shown on the diagram below and define how long you want the boost to dip for in the time interval parameter dS1. To dip the boost when switching between boost levels eg between SP1 and SP2 set GP2=0 and dS2 equal to the amount of time you want the boost to dip for. The solenoid is in fact turned off during the time delay so the waste gate actuator is seeing manifold pressure. You will need to tune the time delay so that your boost does not drop too far during this time delay.
- dS1 and SP1 will be active after a reset by earthing the orange wire through a switch.
- The first time interval will start once green wire has been earthed and un-earthed. If this switch is setup on a clutch mounted the launch time delay dS1 will start when the switch is opened again. On a clutch mounted switch this could be when clutch is released for launch.
- After the time delay associated with dS1 has elapsed, SP1 will continue to be active.
- SP2-6/dS2-6 will be triggered when the green wire is earthed through a switch. For example if the time delay is between gear changes the time will start when switch is closed e.g. on clutch mounted switch when clutch is depressed for the gear change.
- During the time delay the solenoid will be off hard (i.e. actuator seeing manifold pressure) if the gate pressure has been set to zero. Once the time delay has elapsed the boost level will switch to the subsequent set point boost level.

To edit the delayed switching value (e.g. dS1 in bG1); assuming SSD is active in the setup menu under the SL parameter. Hold the **MODE** button and the **BOOST/DOWN** arrow simultaneously to access the **Boost Menu**. Then scroll up or down to the desired boost group (bG1 – bG6), press the **MODE** button again to access the boost group. Scroll to **Delay Switching (dS)** inside the boost group using the **UP** or **DOWN** arrow. Press the **MODE** button to enter the **dS** parameter. The delayed switching value will flash on the readout prompting it is ready to be edited. To change the value, press the up or down arrow and scroll to the desired value. Note these values are set in tenths of a second. Pressing the **MODE** button will save the value and exit back one level. To edit the gate pressure value, follow the normal procedure for editing gate pressure.

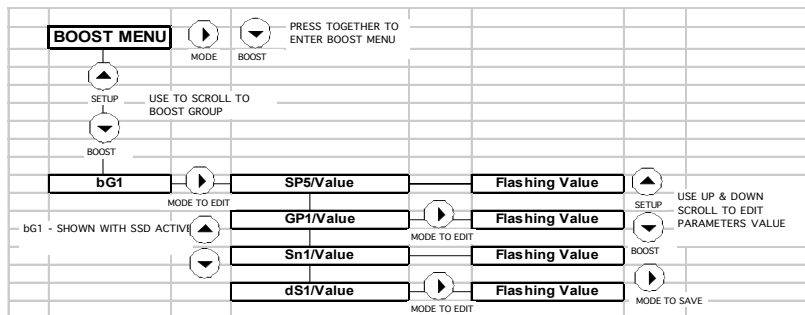

Example Boost Curve - boost dipping

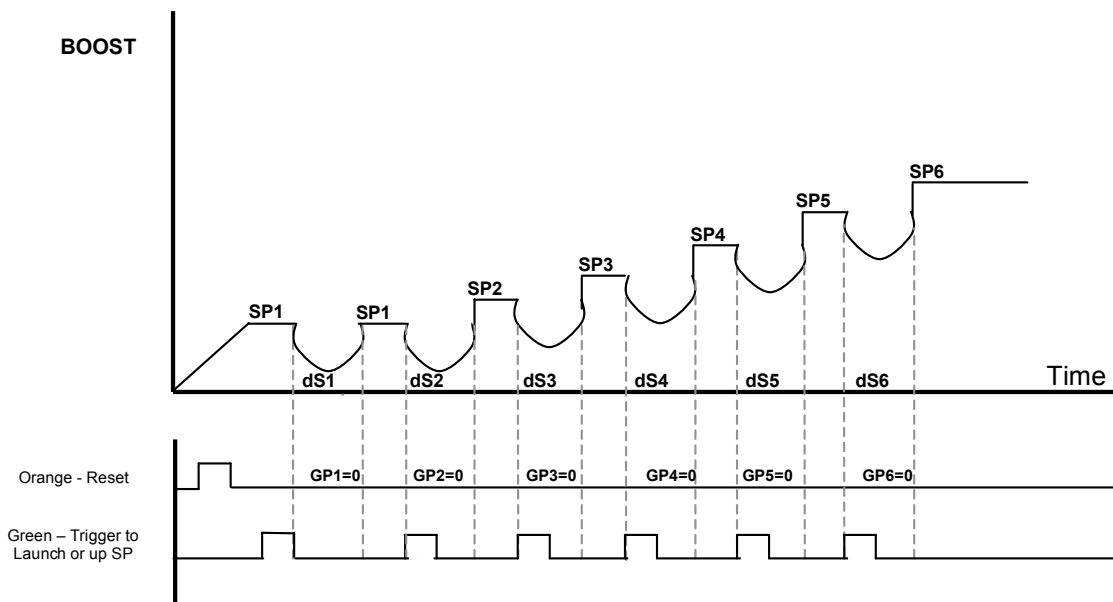

EXAMPLE 2. BOOST SPIKING BETWEEN BOOST LEVEL SWITCHING

- Earthing the green wire will scroll up through set points starting at SP1 up to SP6 one at a time.
- Earthing the orange wire will reset and return to SP1 and dS1 (launch time delay).
- To create a spike in boost during the time delay you must set the gate pressure for the relevant boost level higher than the boost level achieved with the set point. For example if you know that a SP2 value of 40 gives you a boost pressure of 14 psi you can spike your boost pressure to say 17 psi by setting GP2 = 17 psi.
- You must also set the time interval dS during which you want your boost spike.
- If your time interval (dS) expires before your gate pressure spike is reached the boost level will go to the SP boost level.
- If your gate pressure is reached before the time interval dS expires then the time interval will be cut short and the boost level will return to the boost level for the next set point.

Example Boost Curve - Boost Spiking

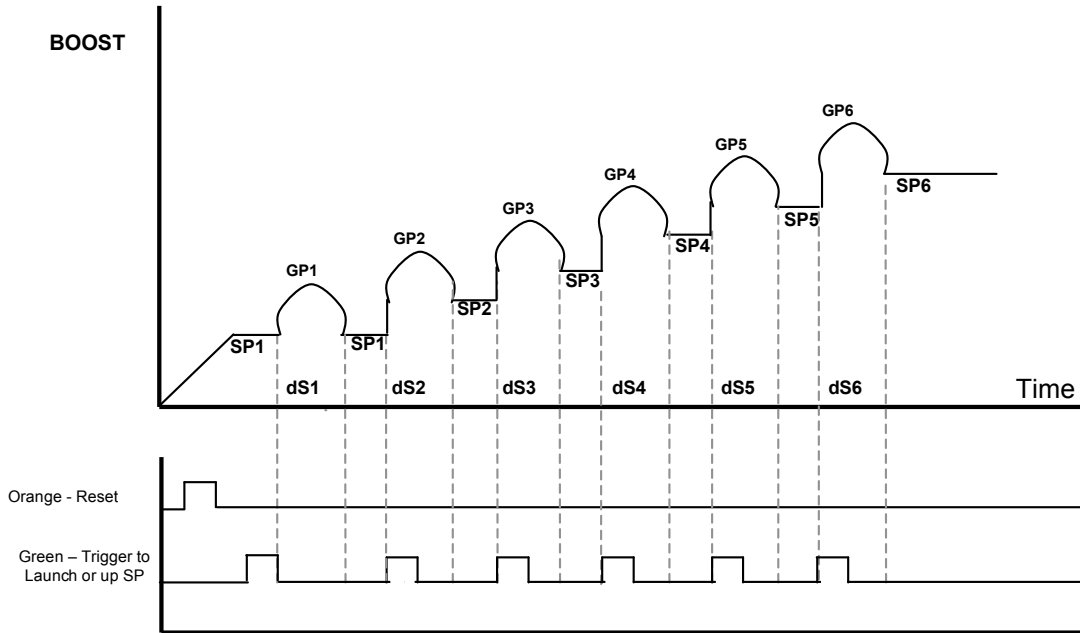

EXAMPLE 3. COMBINATION OF BOOST SPIKING & BOOST DIPPING BETWEEN BOOST LEVEL SWITCHING

- A combination of spikes and dips as shown below can be achieved through entering zero gate pressure where you want a dips and a gate pressure (the max of the spike) where you want a boost spike.
- Combination Curve**

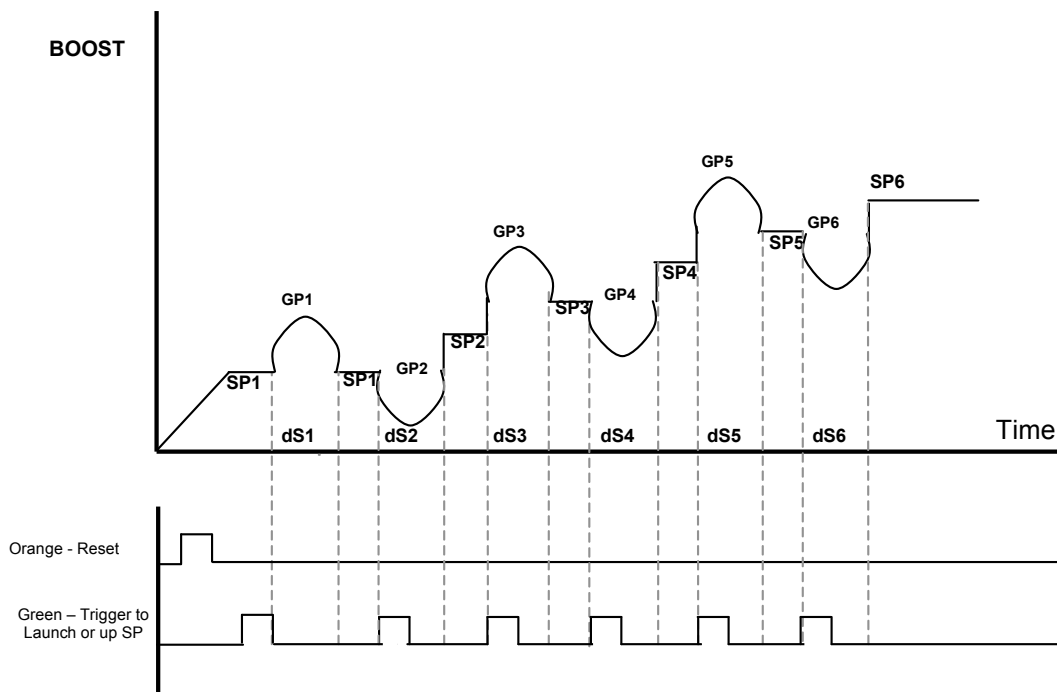

6.8 – SSE - Sequential switching function E

Timed sequential switching function E allows the set-points to be mapped and switched during a predetermined time interval.

- You can enter dS1-6 as the amount of time you wish each mappable set point to be active up to a maximum of 99 seconds. dS can be entered in 0.1s increments – to enter four seconds enter 040.
- Only the first 4 seconds are mappable and the last set point will continue to be active for remainder of the time delay (if set longer than 4 seconds).
- Each boost group can be mapped in 0.2 second increments – i.e. 20 up definable points over the 4 seconds maximum. These increments appear within the each boost group once SSE is turned on in the setup menu. When a time point is first selected it will flash SSE then toggle between the time point and its current set point (e.g. 002 is the first time increment of 0.2s and this number will flash between its current set point which might be 30)
- Entering a value in the SP parameter of the boost group will paste this value through all time increments.
- Gate pressure is not available with this function and will no longer be visible in the boost group.
- dS1 will refer to the amount of time BG1 is active before switching to BG2, dS2 to the amount of time BG2 is active before switching to BG3 and so on.

To edit the delayed switching value (e.g. dS1 in bG1); assuming SSE is active in the setup menu under the SL parameter. Hold the **MODE** button and the **BOOST/DOWN** arrow simultaneously to access the **Boost Menu**. Then scroll up or down to the desired boost group (bG1 – bG6), press the **MODE** button again to access the boost group. Scroll to **Delay Switching (dS)** inside the boost group using the **UP** or **DOWN** arrow. Press the **MODE** button to enter the **dS** parameter. The delayed switching value will flash on the readout prompting it is ready to be edited. To change the value, press the up or down arrow and scroll to the desired value. Note these values are set in tenths of a second. Pressing the **MODE** button will save the value and exit back one level.

To edit the time points enter the boost menu and enter boost group. Scroll up until you reach the first data point the display with flash SSE then toggle between the time point and its current value. For example the first time point is 002 (0.2s) followed by its current set point value. Press **MODE** to edit the time point and scroll **UP** or **DOWN** to your desired set point value. Pressing **MODE** will save the time point. Press **UP** to move on to the next point.

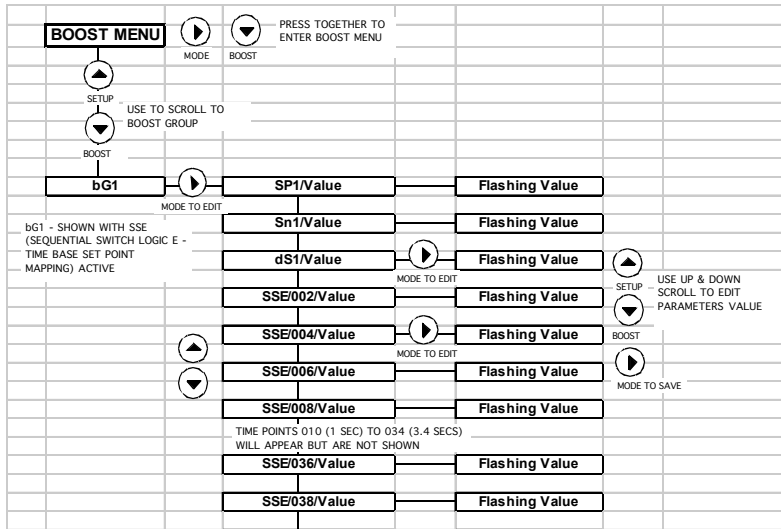

This is a solely time based switching method and will not be dependant on switching except for a reset to SP1 (earthing the orange wire) and a GO (earthing the green wire) which will start the timer.

Example 1. dS1=4s with 4s map defined

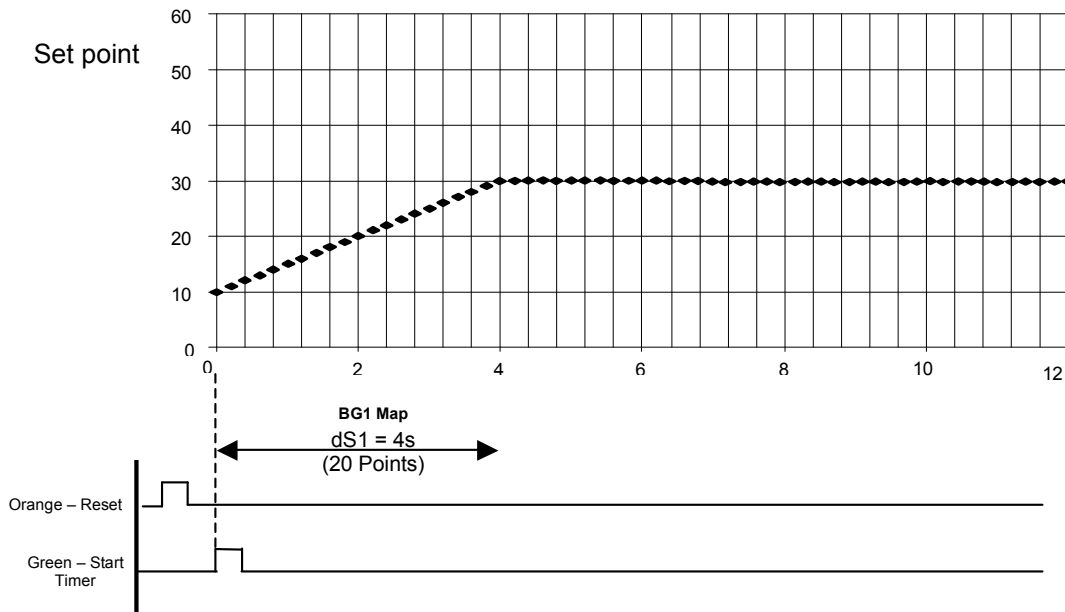

Example 2. dS1=4s, dS2=4s with 8s map defined

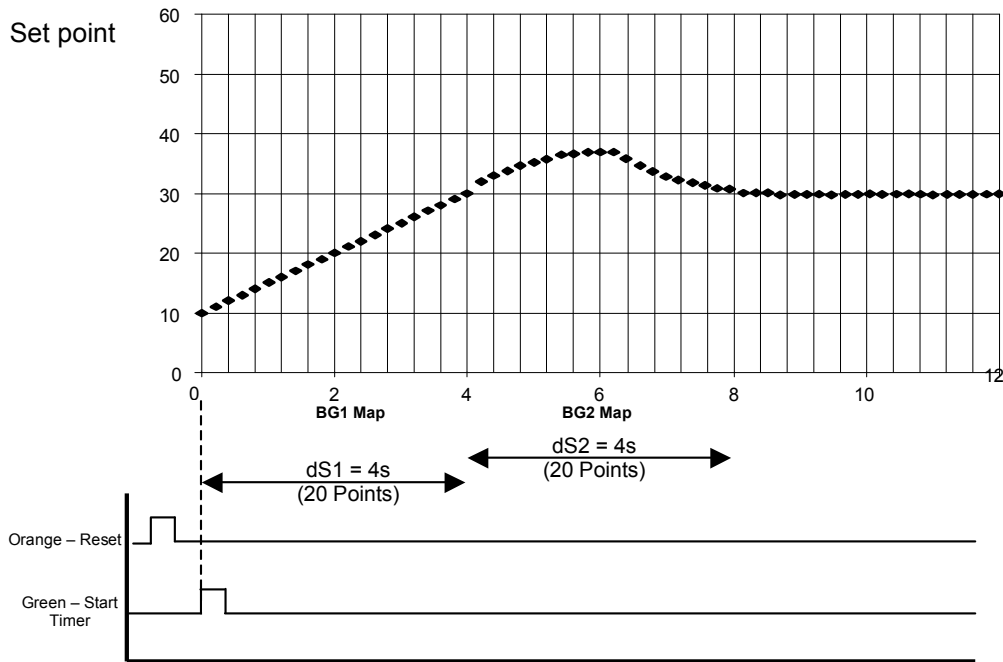

Example 3. dS1-6=4s – Maximum 24s of full mapping

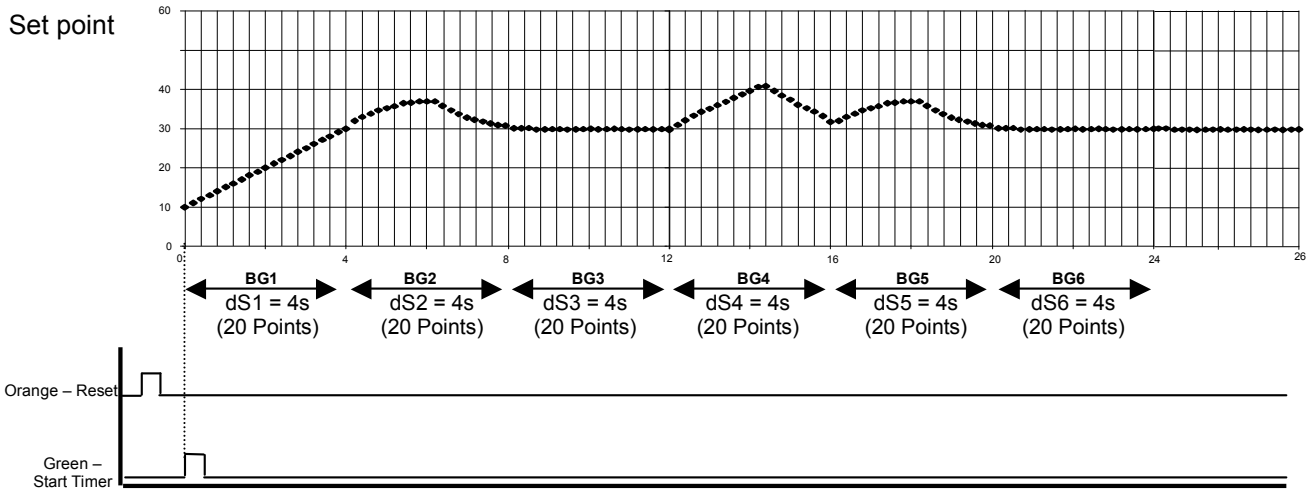

Example 4. Time delays as shown with mapping for first 4s then remainder of dS on last map point

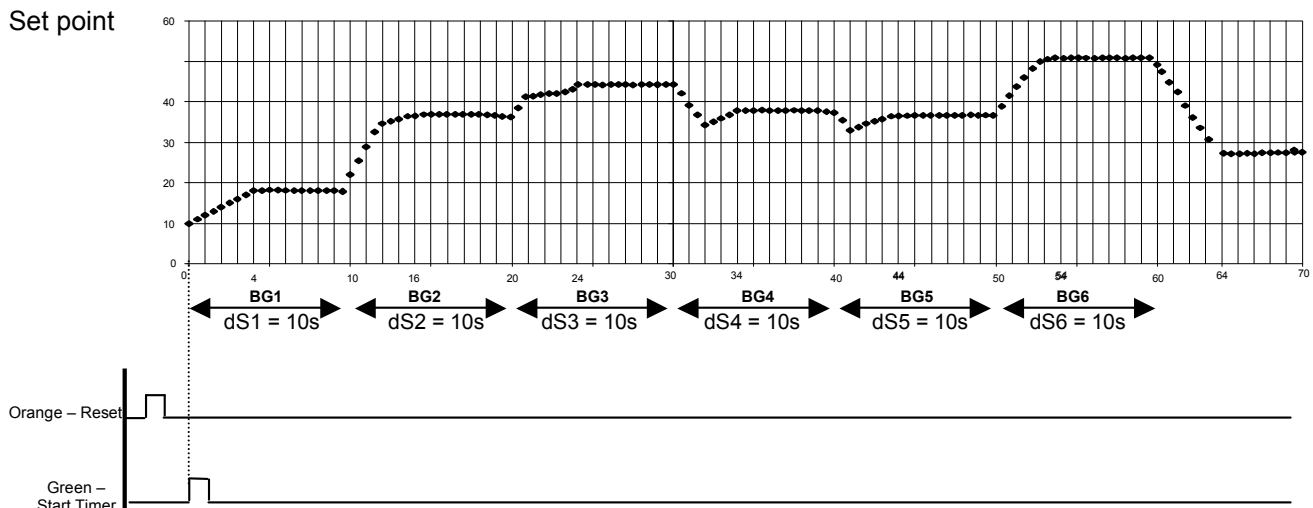

7.0 TROUBLESHOOTING

The following points should be checked if you find that your engine is over-boosting, under-boosting or the boost pressure is fluctuating erratically. Please note the following checks will cure 99% of problems experienced when fitting a Turbosmart e-Boost2.

- Check that the e-Boost solenoid is installed correctly.
- Ensure the factory boost control solenoid is not connected in the hose between the pressure source and the waste gate actuator
- Ensure the length of the waste gate actuator rod has not been modified, refer to the manufactures specifications
- Check to see if the e-Boost solenoid is not blocked or contaminated with dirt, oil build up or debris
- Check the joining hoses for splits, cracks or loose connections and ensure they are not blocked, kinked or restricted, particularly if the existing hose was reused
- Pressure test the waste gate actuator for leakage, the diaphragm or housing may be cracked or split
- Ensure the smooth and free operation of the waste gate arm in the turbo exhaust housing.
- Check that the hose between the e-Boost and the inlet manifold is not obstructed, broken or kinked.
- Check that the OBS is set higher than the boost pressure you are aiming for.
- Check the Blow-off Valve for leakage, some are used as over-boost valves
- Gate pressure maybe set too close to your actual boost pressure
- Ensure correct sensitivity setting.

8.0 VEHICLE SPECIFIC WIRING DIAGRAMS

Following are vehicle specific ECU wiring diagrams for connecting the yellow RPM signal wire. Turbosmart recommends consulting an appropriately qualified technician for this installation. Be sure to count the number of pins and securely connect the yellow RPM wire to the appropriate ECU wire. Be sure to cover any exposed connections with electrical tape.

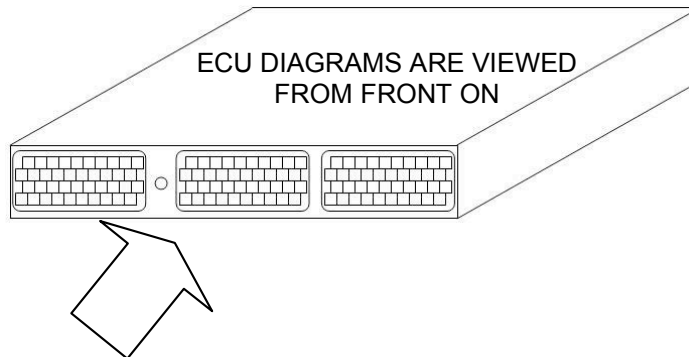

Each diagram has the ECU locations specified by the key and diagram below.

A Passenger Side Lower Dash	F Under the driver seat	K Right of the centre console
B Left of the glove box	G Under the passenger seat	L Engine bay
C Passenger Side foot rest	H Near the steering column	M Front side of the boot
D Behind the glove box	I Right of the meter panel	N Back of the driver seat
E Behind the centre console	J Driver side lower dash	

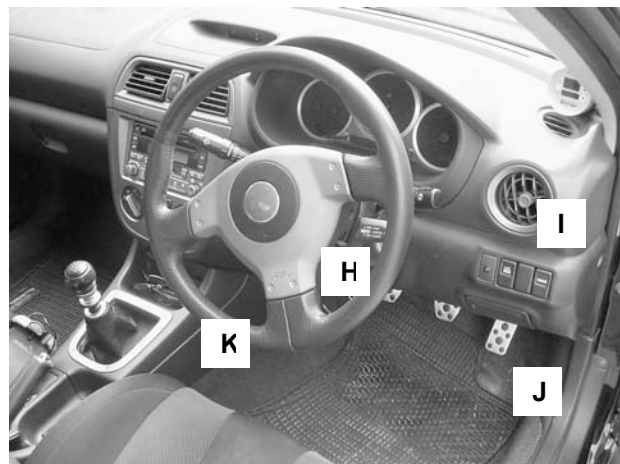
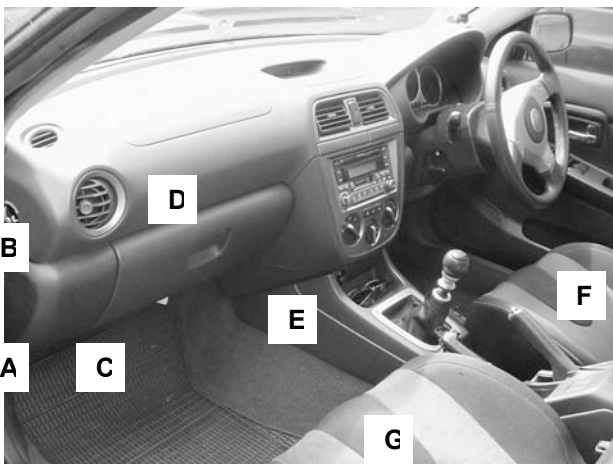

TOYOTA SOARER JZZ30 1JZ-GTE 91.5 ~ ONWARDS ECU location: C

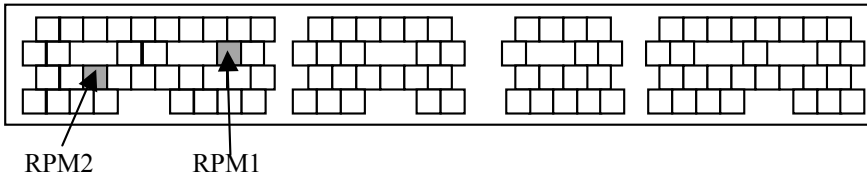

TOYOTA SUPRA JZA80 – 2JZ-GTE ECU location: C

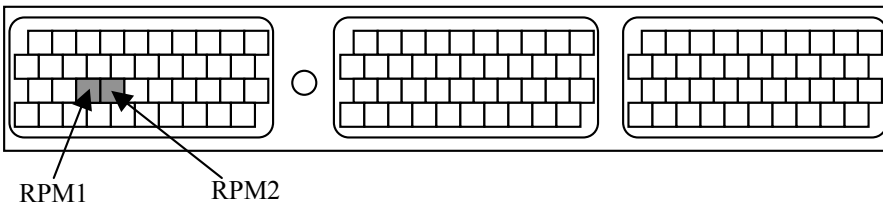

TOYOTA SUPRA JZA80 – 2JZ-GTE M/T ONLY ECU location: C

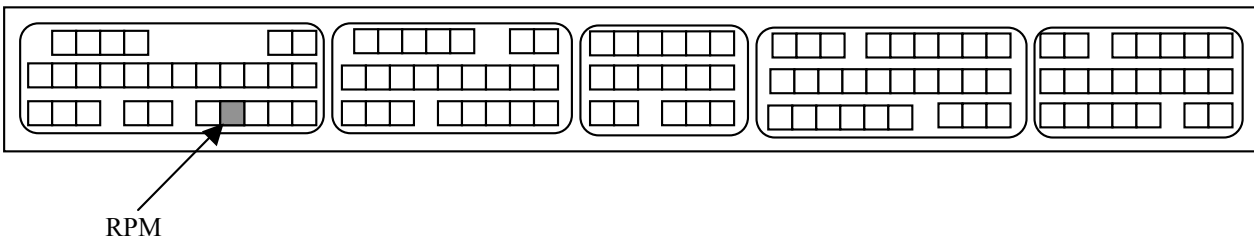

- NISSAN 300ZX Z32 VG30DETT 89.7 ~ ONWARDS ECU location: A**
- NISSAN SKYLINE R33 RB25DET 93.8 ~ 95.12**
- NISSAN SKYLINE R32 RB20DET 89.5 ~ 93.7**
- NISSAN 200SX S14 SR20DET 93.10 ~ 96.5**
- NISSAN SILVIA S13 CA18DET 88.5 ~ 91.1**
- NISSAN 180SX RS13 CA18DET 89.3 ~ 90.12**

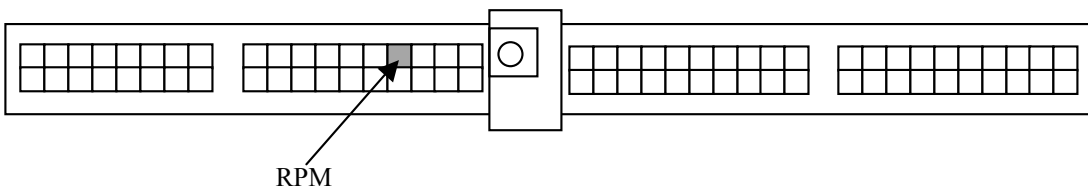

- NISSAN SKYLINE R34 RB26DETT 99.1 ~ ONWARDS ECU location: A**
- NISSAN SKYLINE R33 RB26DETT 95.1 ~ 98.12**
- NISSAN SKYLINE R32 RB26DETT 89.8 ~ 94.12**

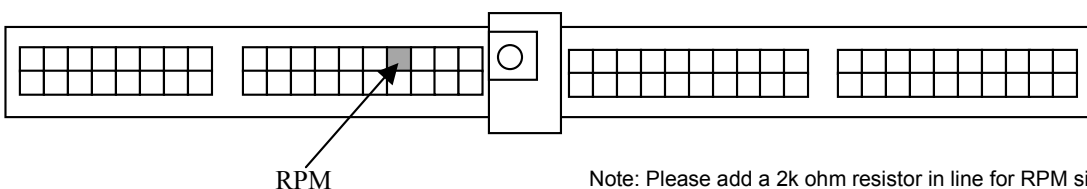

Note: Please add a 2k ohm resistor in line for RPM signal

NISSAN SKYLINE R34 RB25DET 98.5 ~ ONWARDS ECU location: A

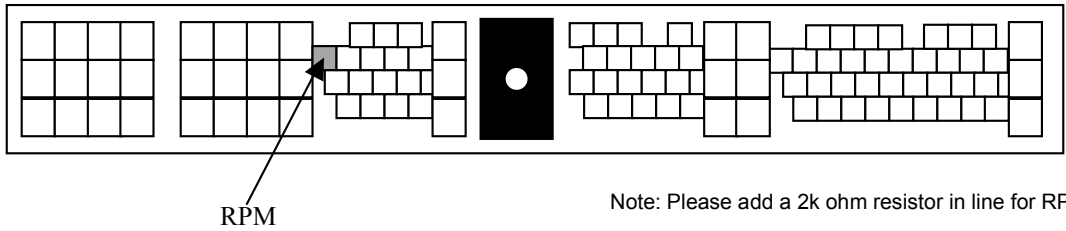

Note: Please add a 2k ohm resistor in line for RPM signal

NISSAN SKYLINE R33 RB25DET 96.1 ~ 98.4 ECU location: A

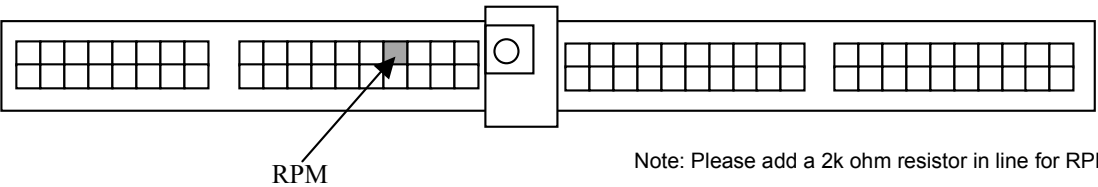

Note: Please add a 2k ohm resistor in line for RPM signal

NISSAN SKYLINE R31 RB20ET 87.8 ~ 89.5 ECU location: A

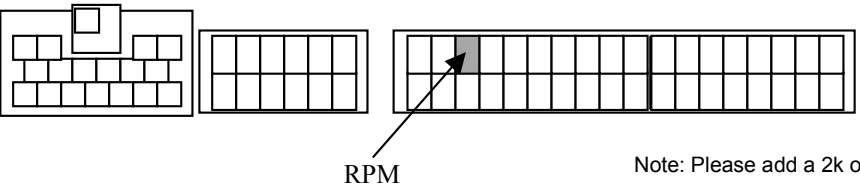

Note: Please add a 2k ohm resistor in line for RPM signal

NISSAN SILVIA S15 SR20DET 99.1 ~ ONWARDS ECU location: A
NISSAN SILVIA S14 SR20DET 96.6 ~ 98.12
NISSAN PULSAR GTIR N14 SR20DET 90.8 ~94.12 ECU location: E

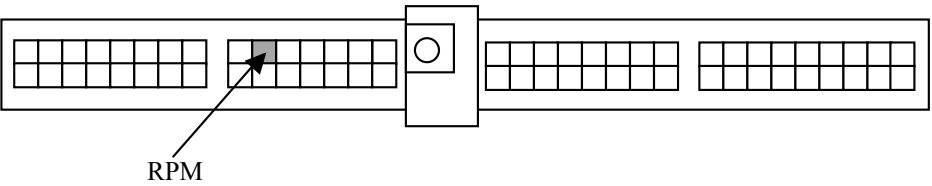

Note: Please add a 2k ohm resistor in line for RPM signal

NISSAN SILVIA PS13 SR20DET 91.1 ~ 93.9 ECU location: A
NISSAN 180SX RPS13 SR20DET 91.1 ~ 96.7

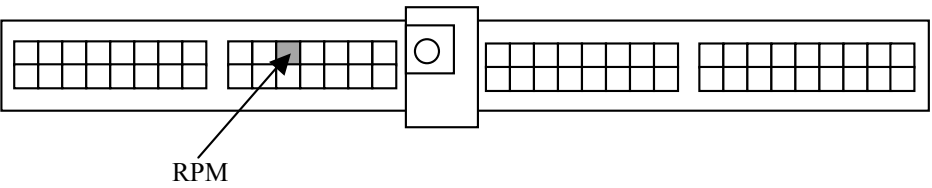

Note: Please add a 2k ohm resistor in line for RPM signal

NISSAN 180SX RPS13 SR20DET 96.8 ~ 98.12 ECU location: A

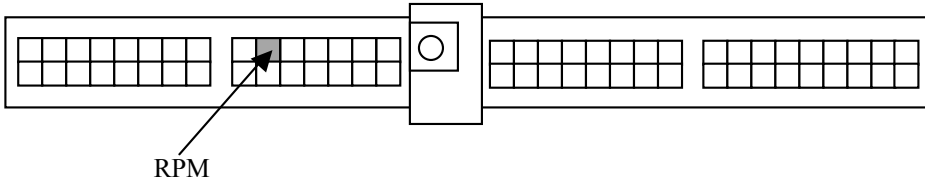

MITSUBISHI GTO Z16A 6G72 90.10 ~ ONWARDS ECU location: E
 MITSUBISHI LANCER CE9A 4G63 93.10 ~96.7 & CD9A 4G63 92.10 ~ 93.9 ECU location: B

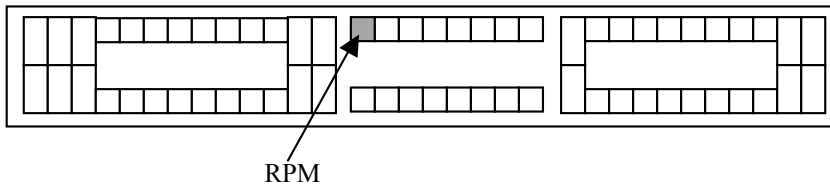

MITSUBISHI ECLIPSE D32A 4G63 95.6 ~ ONWARDS ECU location: E
 MITSUBISHI LANCER CP9A 4G63 99.1 ~ ONWARDS ECU location: B
 MITSUBISHI LANCER CP9A 4G63 98.1 ~ 98.12
 MITSUBISHI LANCER CN9A 4G63 96.8 ~ 97.12

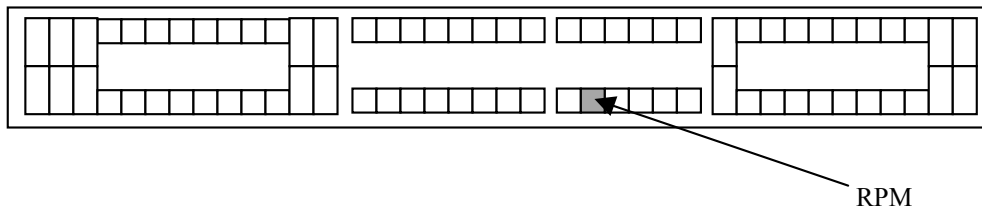

Note: For your rpm signal to work correctly with this ECU you may need to place a 3.3K ohm ¼ watt resistor (Colour code: orange, orange, orange, gold) in series with the yellow rpm input wire before connecting to the ECU.

MITSUBISHI ECLIPSE D27A 4G63 89.11 ~ 95.6 ECU location: E

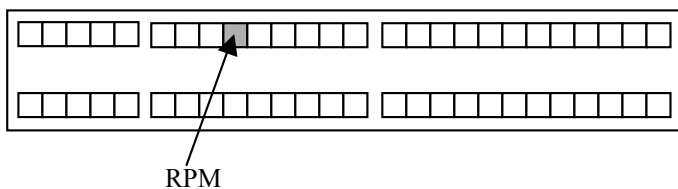

MAZDA RX-7 FC3S 13B 88.9 ~91.11 ECU location: C

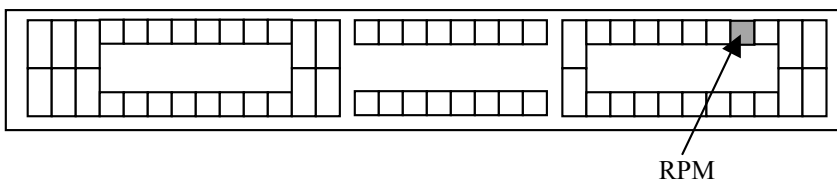

MAZDA RX-7 FD3S 13B-REW 91.12 ~95.11 ECU location: A

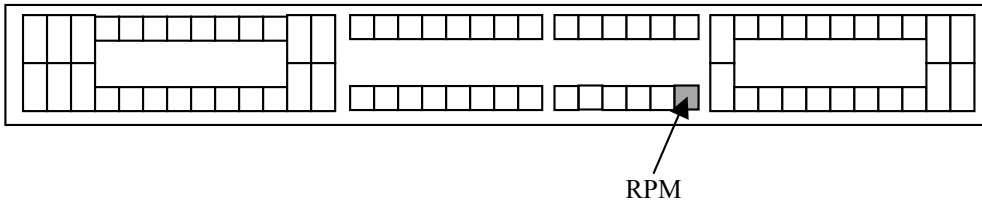

MAZDA RX-7 FD3S 13B-REW 95.12 ~ONWARDS ECU location: A

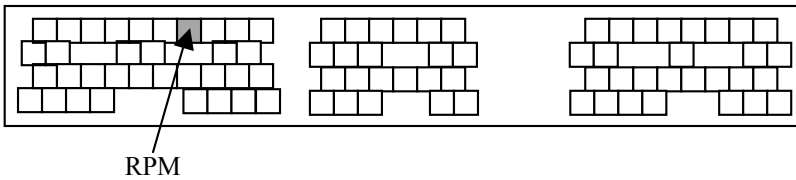

MAZDA RX-7 FC3S 13B 85.19 ~88.8 ECU location: C

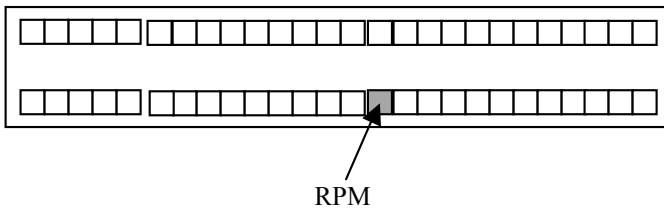

SUBARU LEGACY BC5 & BF5 EJ20G 89.2 ~ 93.9 ECU location: H

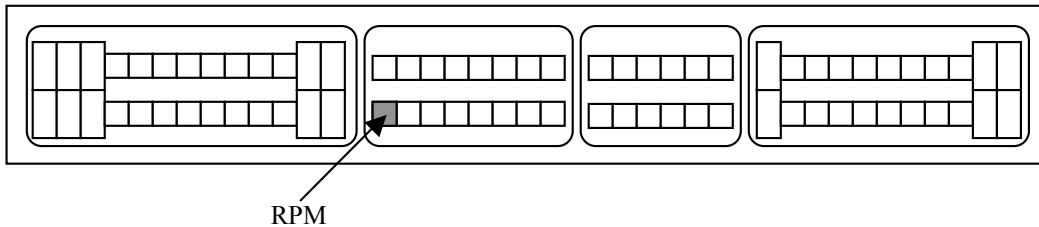

SUBARU IMPREZA GC8 EJ207 & GF8 EJ205 98.9 ~ ONWARDS ECU location: C

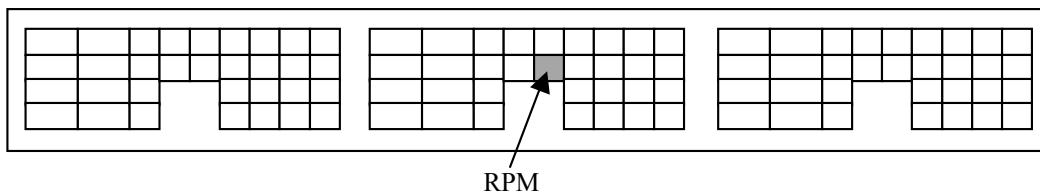

Note: For your signal to work correctly with this ECU you will need to place a 2K ohm ¼ watt resistor (Colour code: red, black, red, gold) in series with the yellow rpm input wire before connecting to the ECU.

SUBARU IMPREZA GC8 & GF8 EJ20K 96.9 ~ 98.8 ECU location: C

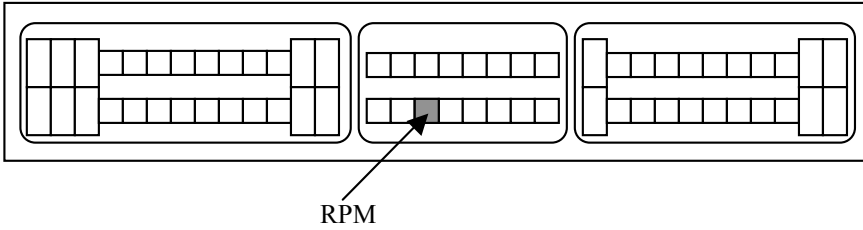

SUBARU LEGACY BD5 & BG5 EJ20H 93.10 ~ 96.5 ECU location: C

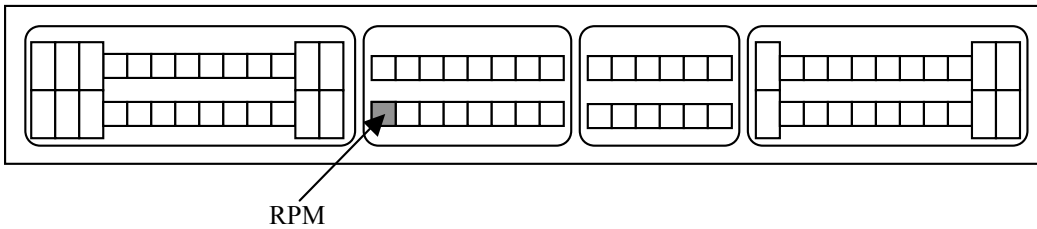

SUBARU LEGACY BD5 & BG5 EJ20H A/T 96.6 ~ 98.5 ECU location: C

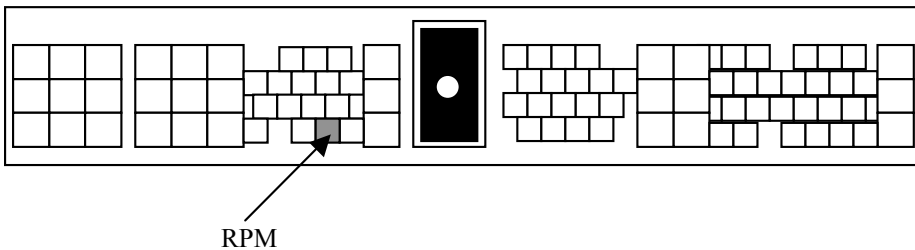

SUBARU IMPREZA WRX 2002 ECU location: C

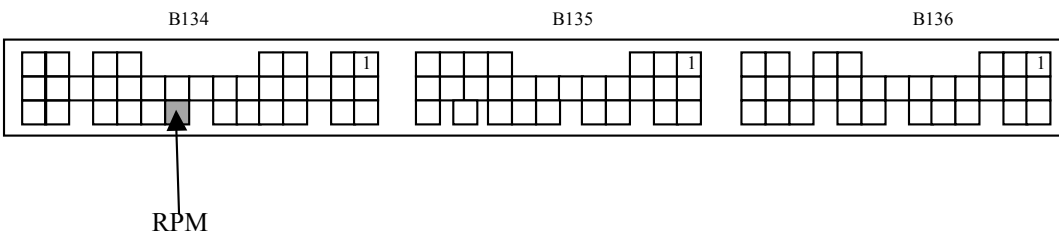

SUBARU LIBERTY B4 ECU location: C

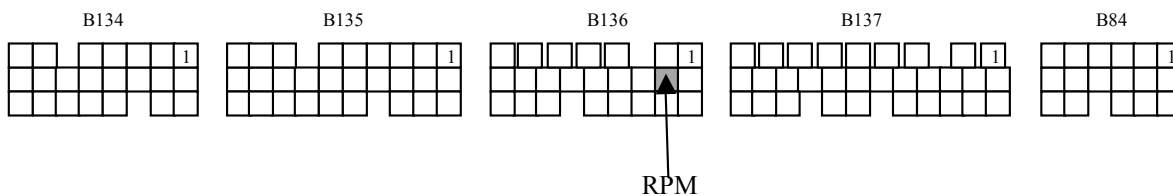

SUBARU STI 01 - 02 ECU location: C

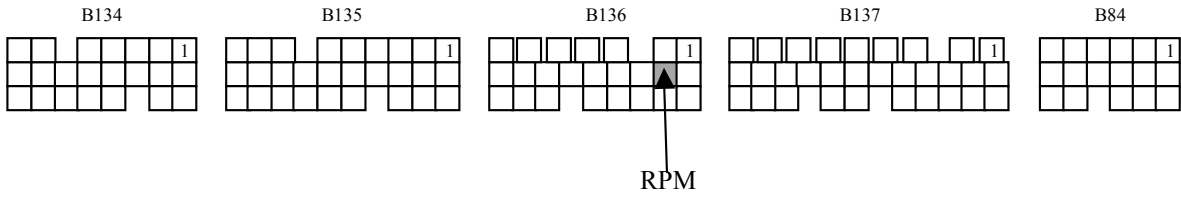

SUBARU STI 03 - 04 ECU location: C

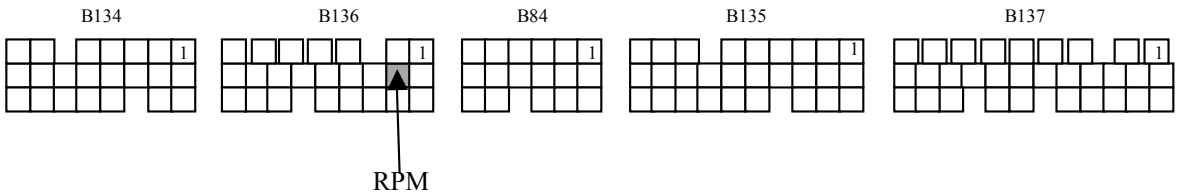

The Turbosmart Pledge

TURBOSMART ONE YEAR LIMITED WARRANTY

Turbosmart is a company built on Customer Satisfaction and Service. That is why all of our products go through regimented test procedures before they are packaged and shipped. Turbosmart stands behind its products for one full year after purchase. Terms of Warranty, Service and Returns are as follows:

Limited Warranty: Turbosmart warrants its products to be free from defects in material and workmanship under normal use and if properly installed for a period of one year from date of purchase. If found to be defective, it will be replaced or repaired if returned prepaid along with proof of date of purchase. This shall constitute the sole remedy of the purchaser and the sole liability of Turbosmart to the extent permitted by law, the foregoing is exclusive and in lieu of all other warranties or representations whether expressed or implied, including any implied warranty of merchantability or fitness. In no event shall Turbosmart be liable for special or consequential damages. This warranty is only valid on products purchased from Turbosmart Authorized Dealers.

Service: After the warranty period has expired, repair service is charged based on a minimum and maximum charge rate. (Contact Customer Service for current rate).

Returns: When returning a Turbosmart product for repair, it must be accompanied by a completed Customer Warranty Form and RMA number. To access this form please go to our website www.turbosmartonline.com and you will find it on the Downloads page.

THE TURBOSMART PLEDGE

DO NOT USE ANY TURBOSMART PRODUCT UNTIL YOU HAVE CAREFULLY READ AND UNDERSTOOD THE FOLLOWING AGREEMENT.

Please call if you have any questions or do not understand this agreement. Refer to our brochure, website or catalogue for terms and conditions and further information regarding your product. Turbosmart appreciates your business and pride ourselves on our customer service. We are always happy to offer you advice and will provide you with help in any way we can. The purpose of this agreement is to avoid any problems or hard feelings.

We sometimes make mistakes, as do our dealers, distributors and suppliers. Even customers can sometimes order the wrong parts. Do not use, modify, install, trial assemble, nick, drop, scratch or adjust any part until you first check for any damage. Damage must be reported immediately. NO EXCEPTIONS. If there are any components missing please contact your authorized reseller immediately upon receipt of your shipment. Missing components must be reported within five (5) business days of receipt. Parts returned for any reason MUST BE IN RESALABLE CONDITION. It is YOUR responsibility, "THE CUSTOMER" to carefully package any returns to avoid shipping damage. Insurance is highly recommended. Credit cannot be issued for damaged goods.

Turbosmart warrants the quality of the products it designs and manufactures to be free of defects in material and workmanship. This limited warranty is extended only to the original purchaser and may not be transferred or assigned. This limited warranty applies to any product, which after careful inspection by Turbosmart, after receipt of the product from our authorized reseller, is found to have a defect in either material or workmanship. Any modifications to the product will void any and all warranties and will not be exchanged. Before installation, check new car warranty. Turbosmart is not responsible for voiding any original manufactures warranty.

All warranty claims must be returned to the nearest Turbosmart Office, you must return the product and sales receipt, at your own expense, accompanied by the Customer Warranty Form stating the reason for the claim. Proof of purchase must be provided with any warranty claim and will be verified with the authorized reseller from which the product was purchased.

If all the above procedures are followed, and the product is found to be defective in either workmanship or material, Turbosmart shall either repair or replace the product, at its sole discretion, and sole cost. This limited warranty does not cover or apply to any personal injury, labor charges or any other incidental costs or damages caused by the defective product. The individual purchaser acknowledges and agrees that the disclaimer of any liability for personal injury is a material term for this agreement and the individual purchaser agrees to indemnify Turbosmart and to hold Turbosmart harmless for any claim related to the item of the equipment purchased. Under no circumstances will Turbosmart be liable for any damages or expenses by reason of use or sale of any such equipment.

THIS LIMITED WARRANTY IS THE ONLY EXPRESS WARRANTY, WHICH APPLIES TO TURBOSMART PRODUCT AS EXPRESSLY GIVEN IN LIEU OF ANY OTHER WARRANTY EXPRESSED OR IMPLIED, INCLUDING THAT OF MERCHANTABILITY. ANY IMPLIED WARRANTY INCLUDING THAT OF MERCHANTABILITY AND/OR FITNESS FOR A PARTICULAR PURPOSE IS HEREBY LIMITED BY THE SAME TERMS AND TIME LIMITATIONS SET FORTH IN THIS LIMITED EXPRESS WARRANTY AND OTHERWISE EXCLUDED. EXCEPT FOR THOSE OBLIGATIONS ASSUMED HEREIN, TURBOSMART ASSUMES NO OTHER OBLIGATIONS IN CONNECTION WITH THE SALE OF ITS PRODUCTS.

IN THE EVENT THAT THE INDIVIDUAL PURCHASER DOES NOT AGREE WITH THIS AGREEMENT THE BUYER MAY PROMPTLY RETURN THIS PRODUCT, IN A NEW AND UN-USED CONDITION, WITH A DATED PROOF OF PURCHASE, TO THE PLACE OF PURCHASE WITHIN SEVEN (7) DAYS FROM THE DATE OF PURCHASE FOR A FULL REFUND. THE INSTALLATION OF THIS PRODUCT INDICATES THAT THE INDIVIDUAL PURCHASER HAS READ AND UNDERSTOOD THIS AGREEMENT AND ACCEPTS ITS TERMS AND CONDITIONS.

Happy motoring!
The Turbosmart Team.

Head Office: Turbosmart Pty Limited, PO Box 264 Croydon, NSW, 2132 Australia
USA Office: Turbosmart USA, 1185 Park Center Drive, Suite Q, Vista CA 92081 USA

Ph: +61(2) 9798 2866
Ph: (760) 727 7610

Fax: +61 (2) 9798 2826
Fax: (760) 727 7963

Email: info@turbosmart.com.au
Email: sales@turbosmartusa.com